



The Most Accurate Atomic Force Microscope

Park NX-HDM

Automatic Defect Review
and Sub-Angstrom Surface Roughness Measurement
for Media and Substrates





Park NX-HDM

Simply the best AFM for automatic defect review and surface roughness measurement

Higher Throughput, Automatic Defect Review

The task of identifying nanoscale defects is a very time consuming process for engineers working with media and flat substrates. Park NX-HDM is an atomic force microscopy system that speeds up the defect review process by an order of magnitude through automated defect identification, scanning and analysis. Park NX-HDM links directly with a wide range of optical inspection tools, thus significantly increasing the automatic defect review throughput.

Sub-Angstrom, Surface Roughness Measurement

Increasingly, industries require ultra-flat media and substrate to address the ever-shrinking device dimensions. Park NX-HDM provides accurate sub-angstrom surface roughness measurements, scan after scan. Park NX-HDM, together with its industry's lowest noise floor, and its unique True Non-Contact™ technology, it is the most accurate AFM for surface roughness measurement in the market.



Park NX-HDM

Powerful features for high throughput and low operating cost

Automatic Defect Review for Media and Substrates

- Fast defect imaging in non-contact mode
- Automated survey scan of defects mapped by optical inspection tools
- Automated zoom-in scan of specified defects
- Automated analysis of imaged defect types
- Links to a wide range of automated optical inspection (AOI) tools

Accurate Sub-Angstrom Surface Roughness Measurement

- Automated surface roughness measurements for media and substrates
- Industry's lowest system noise of less than 0.5 angstrom rms
- Immunity from parameter-dependent results by True Non-Contact™ technology
- True Non-Contact™ maintains accuracy without degradation in scan resolution
- Automatic tip exchange module (optional)

Cost Savings with True Non-Contact™ Mode

- 10 times or longer tip life during general purpose and defect imaging than any other AFMs
- Minimal tip wear from prolonged high-quality scans
- Minimized sample damage or modification

Accurate AFM Topography with Low Noise Z Detector

- True Sample Topography™ without edge overshoot or piezo creep error
- Accurate surface height recording, even during high-speed scanning
- Industry leading forward and backward scan gap of less than 0.15%

Park NX-HDM

Productivity meets Accuracy

Automatic Defect Review for Substrates & Media

The Automatic Defect Review (Park ADR) in the NX-HDM speeds up and improves the way defects in substrates and media are identified, scanned, and analyzed. Using the defect location map provided from an optical inspection tool, Park ADR automatically goes to each of those locations, and images the defects in two steps: (1) image a larger, survey scan to refine the defect location, (2) then image a smaller zoom-in scan to obtain the details of the defect. Test runs with real defects demonstrate a 10x increase in throughput for defect review in an automated process compared to conventional methods.

Automatic Transfer and Alignment of Defect Maps to AFM

Utilizing an advanced proprietary mapping algorithm, the defect map obtained from automated optical inspection (AOI) tool is accurately transferred and mapped onto Park NX-HDM. This technology allows full automation for high throughput defect imaging.

Map of Defect Coordinates from an Optical Inspection Tool

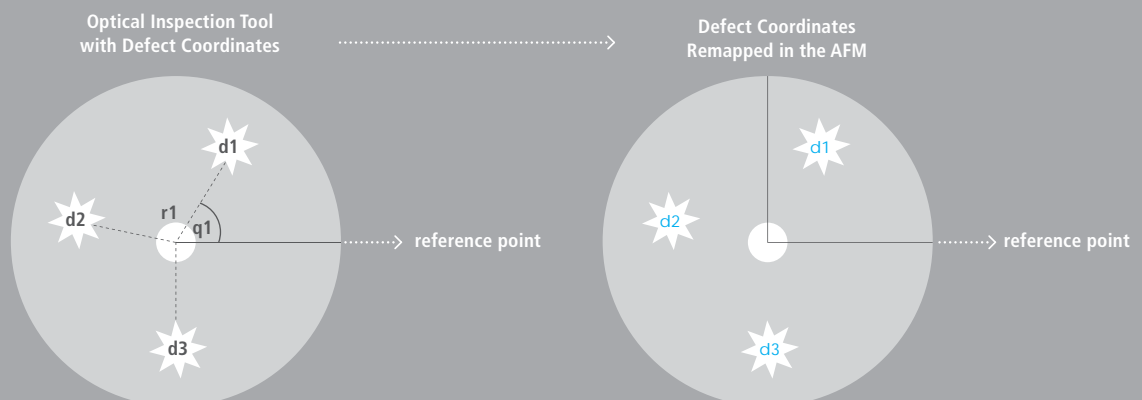

Automated Search Scan & Zoom-in Scan

Optimized scan parameters enable a fast two step scan: (1) a quick, low resolution search scan to locate the defect, then (2) a high resolution zoom-in scan to obtain defect details. The scan size and scan speed parameters are adjustable to match the user's need.

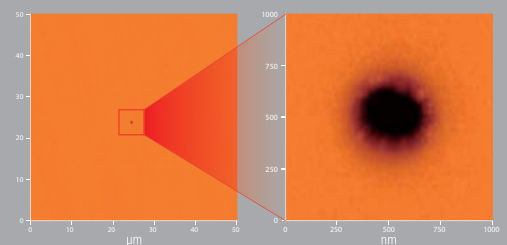

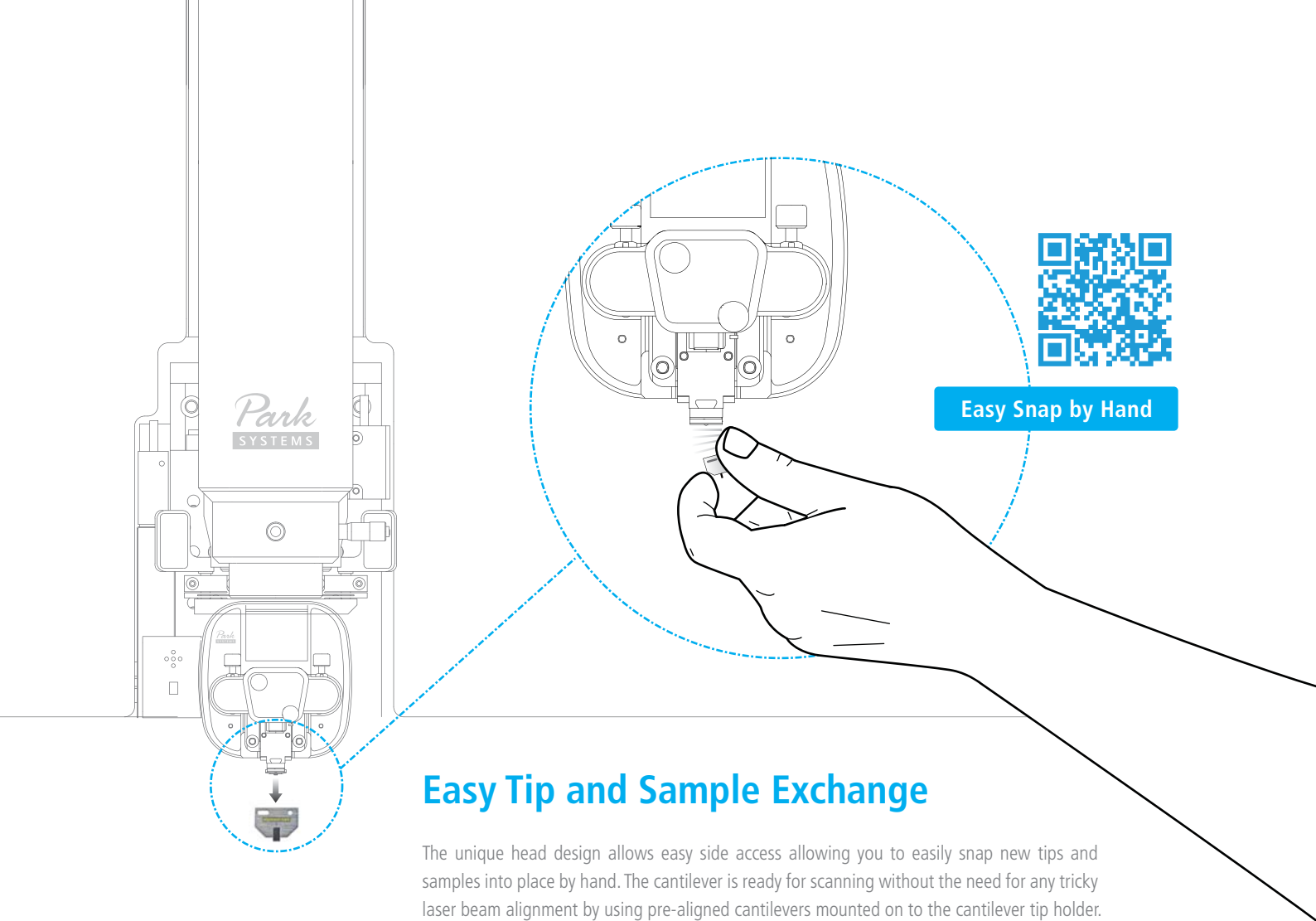

Easy Snap by Hand

Easy Tip and Sample Exchange

The unique head design allows easy side access allowing you to easily snap new tips and samples into place by hand. The cantilever is ready for scanning without the need for any tricky laser beam alignment by using pre-aligned cantilevers mounted on to the cantilever tip holder.

Easy, Intuitive Laser Beam Alignment

With our advanced pre-aligned cantilever holder, the **laser beam** is focused on the cantilever upon placement. Furthermore, the natural on-axis top-down view, the only one in the industry, allows you to easily find the laser spot. Since the laser beam falls vertically on the cantilever, you can intuitively move the laser spot along the X- and Y-axis by rotating its two positioning knobs. As a result, you can easily find the laser and position it on PSD using our beam alignment user interface. From there, all you will need is a minor adjustment to maximize the signal to start acquiring the data.



Laser beam is always focused on the cantilever upon replacement

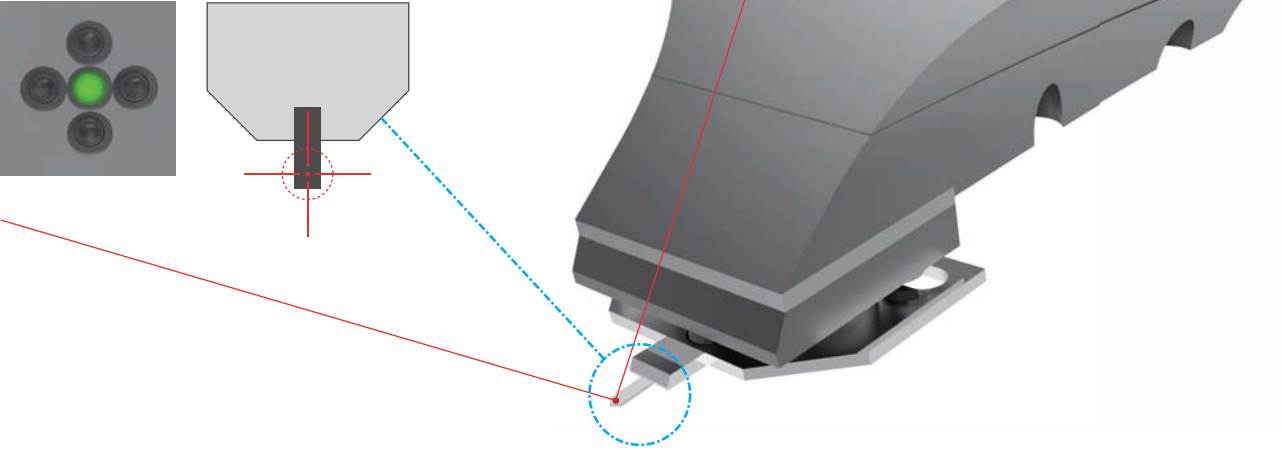

Park NX-HDM

Powerful and yet reliable AFM

Industry's Lowest Noise Floor

To detect the smallest sample features, and image the flattest surfaces, Park has engineered to achieve the industry's lowest noise floor specification of $< 0.5\text{\AA}$. The noise floor data is determined using a "zero scan." The system noise is measured with the cantilever in contact on the sample surface at a single point under the following conditions:

- 0 nm x 0 nm scan, staying at one point.
- 0.5 gain in contact mode
- 256 x 256 pixels

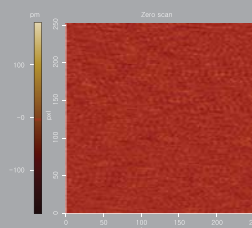

Typically 0.3\AA rms or lower

Statistics

Region	Mid(pm)	Mean(pm)	Rpv(pm)	Rq(pm)	Ra(pm)
Red	0.000	-0.011	359.496	30.025	19.177

Gauge Repeatability and Reproducibility

Due to the ever-decreasing size of components, manufacturers now require the highest level of quality control. Park AFM can provide 1 gauge sigma of less than 1 angstrom.

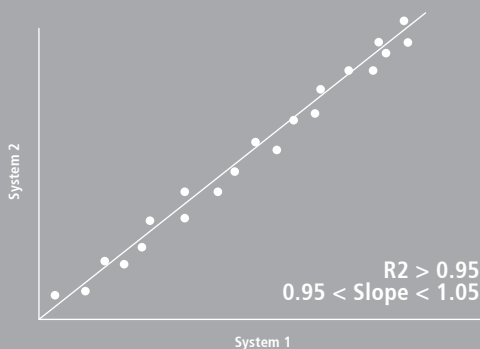
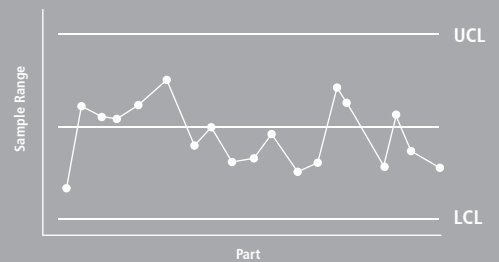

Tool-to-tool Correlation

Thanks to Park's revolutionary AFM platform that was designed for industrial metrology, Park NX-HDM will correlate with any existing Park AFMs that have been previously used for manufacturing, inspection, analysis, or research.

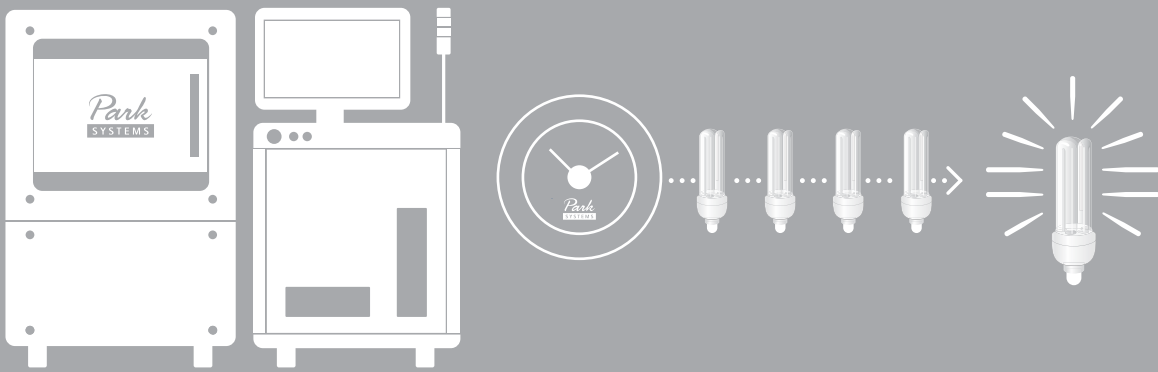

System Uptime

Our engineers and scientists have adopted the most rigorous industry standard product development to ensure the highest level of system reliability. Park NX-HDM can be incorporated seamlessly either as an inline or as an offline inspection tool, with minimal maintenance requirements.



Service and Maintenance

Park is committed to the highest level of service and support. We put every effort to understand our customers' needs. We place the highest priority in meeting promised delivery dates, guaranteed quality, and thorough after-sales service.

Park NX-HDM

Park AFM technology

Industry Leading Low Noise Z Detector

Our AFMs are equipped with the most effective low noise Z detectors in the field, with a noise of 0.2 Å over large bandwidth. This produces highly accurate sample topography, no edge overshoot and no need for calibration. Just one of the many ways Park NX-HDM saves your time and gives you better data.

Accurate Sample Topography Measured by Low Noise Z Detector

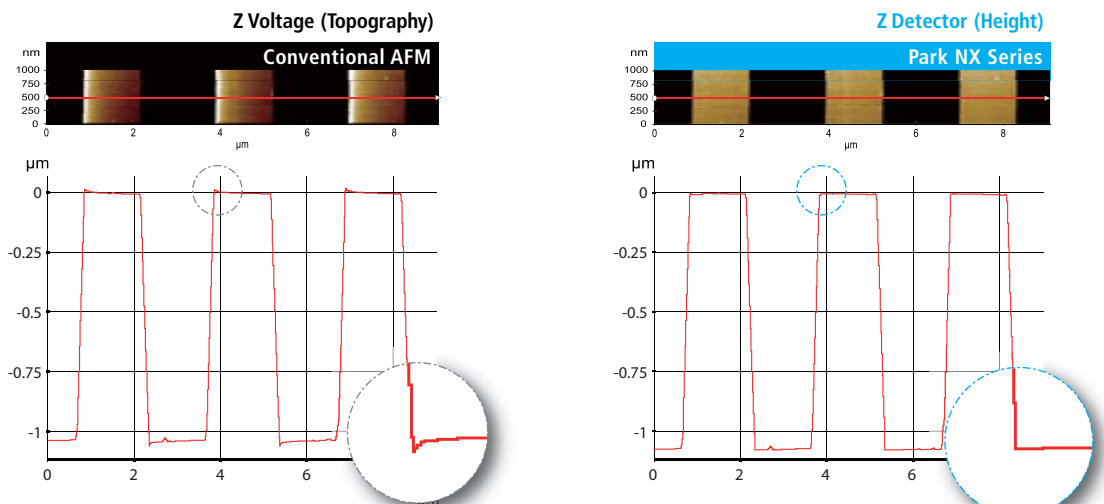

Sample: 1.2 μm Nominal Step Height (9 μm x 1 μm, 2048 pixels x 128 lines)

Piezoelectric creep effect

No creep effect

No artifact by AFM scanner in low noise closed-loop topography

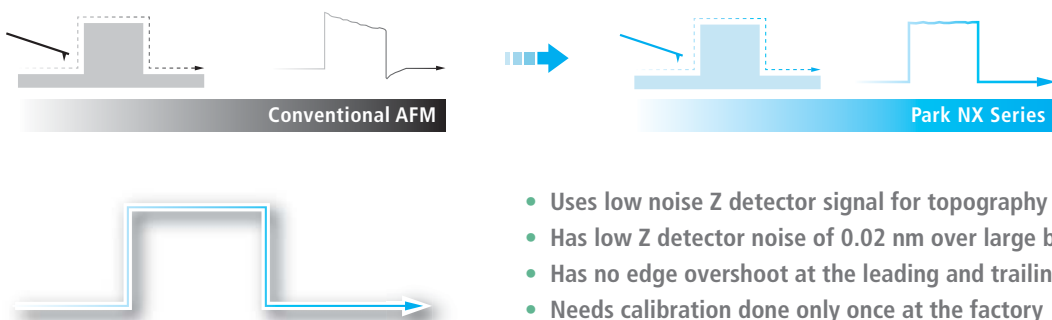

- Uses low noise Z detector signal for topography
- Has low Z detector noise of 0.02 nm over large bandwidth
- Has no edge overshoot at the leading and trailing edges
- Needs calibration done only once at the factory

True Non-Contact™ Mode Preserves Sharp Tip

AFM tips are so brittle that touching a sample will instantly reduce the resolution and quality of the image they produce. For soft and delicate samples, the tip will also damage the sample and result in inaccurate sample height measurements, something that can cost you valuable time and money.

True Non-Contact™ mode, a scan mode unique to Park AFMs, consistently produces high resolution and accurate data while maintaining the integrity of the sample.

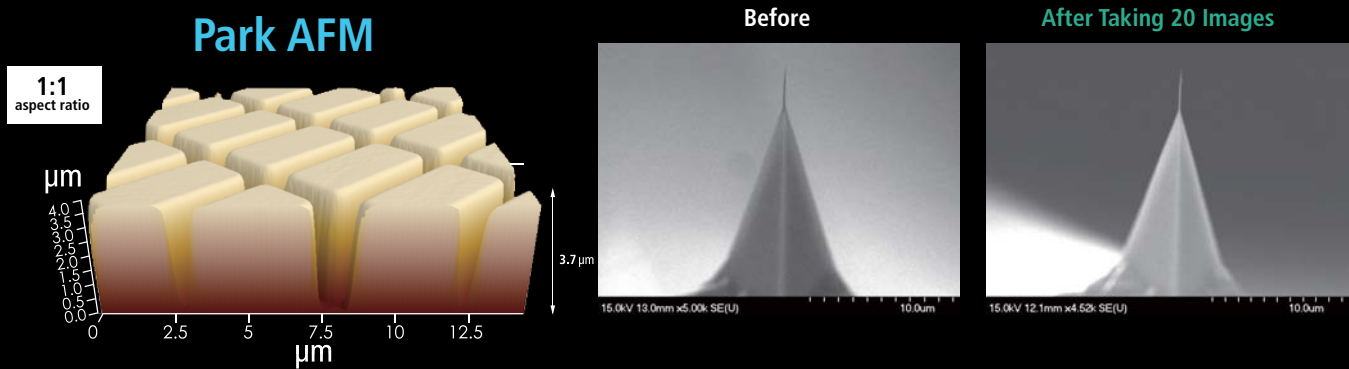

Accurate Feedback by Faster Z-servo enables True Non-Contact AFM

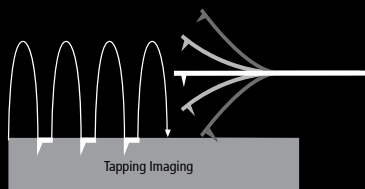

Tapping Imaging

- Quick tip wear = Blurred low-resolution scan
- Destructive tip-sample interaction = Sample damage and modification
- Highly parameter-dependent



True Non-Contact™ Mode

- Less tip wear = Prolonged high-resolution scan
- Non-destructive tip-sample interaction = Minimized sample modification
- Immunity from parameter dependent results

Park NX-HDM

The most innovative AFM technology in one powerful package

Low Noise XYZ Position Sensors for more accurate scans

The NX-HDM provides you with unprecedented accuracy in topography height measurement by utilizing its ultra-low noise Z detector instead of the commonly used Z voltage signal that is non-linear in nature. Industry leading low noise Z detector replace the applied Z voltage as the topography signal and make the forward and backward scan gap a negligible 0.15% of the scan range.

Minimal Thermal Drift and Hysteresis reduces tip drift

The body of the NX-HDM is designed to be extremely mechanically and thermally stable, minimizing thermal drift and giving you more precise measurements. A typical thermal drift rate is less than 100 nm/°C for the lateral direction and 200 nm/°C for the vertical direction.

Automatic Measurement Control so you can get accurate scans with less work

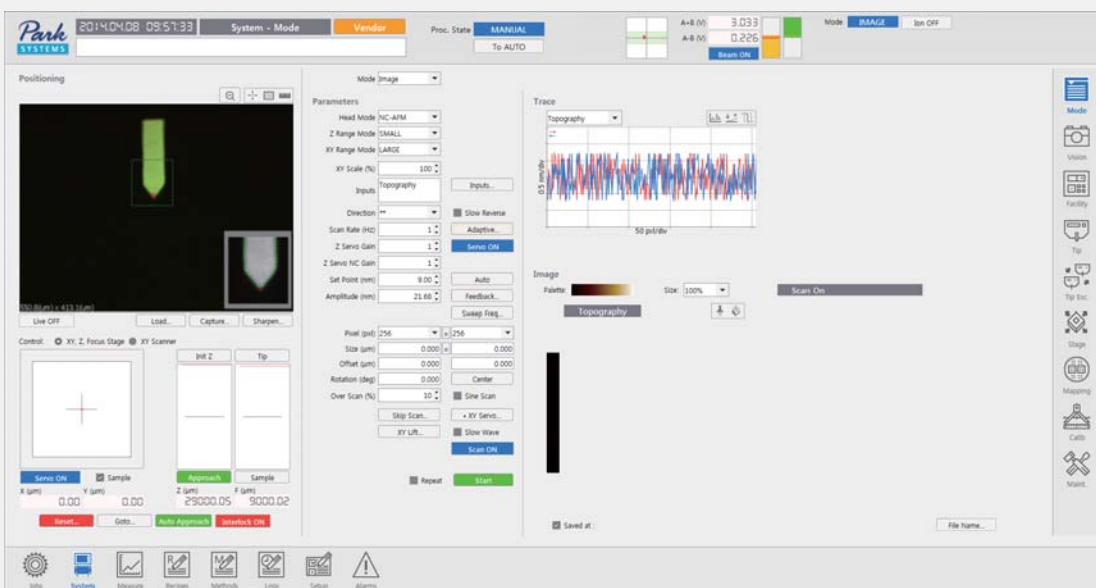

The NX-HDM is equipped with automated software that makes operation nearly effortless. Just select the desired measurement program to get precise multi-site analysis with optimized setting for cantilever tuning, scan rate, gain, and set point parameters as a recipe.

Park's user-friendly software interface gives you the flexibility to create customized operation routines (recipes) so you can access the full power of the NX-HDM and get the measurements you need.

Creating new recipes is easy. It takes about 10 minutes to create a new routine from scratch, or less than 5 minutes to modify an existing one.

Park NX-HDM's automated system features:

- Auto, semi-auto, and manual mode so you have complete control
- Editable measurement method for each automated routine
- Live monitoring of the measurement process
- Automatic analysis of acquired measurement data

Options

Customize your AFM to make it more efficient and more effective

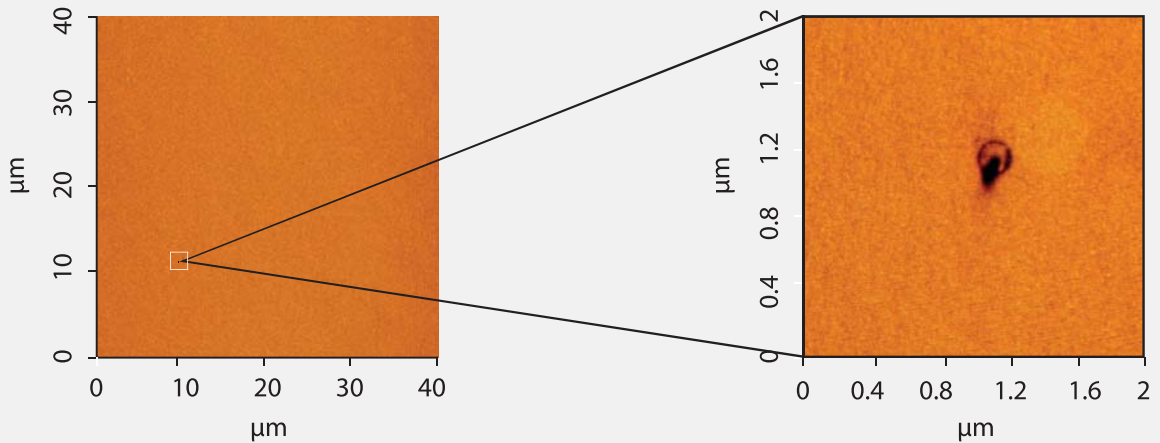

Automatic Defect Review (ADR) to locate defects quickly and easily

The integrated ADR software lets you easily initiate a fully automated search and imaging routine for specified defects. The ADR software automatically goes to each of defect location and images the defects in two ways: (1) a larger survey scan to refine the defect location, (2) then a smaller zoom-in scan so you can see the defect in greater detail.

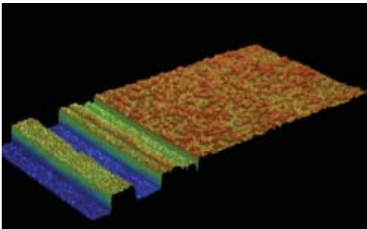

Automatic PTR Measurement and Analysis lets you measure sliders with less work

The NX-HDM's integrated automatic pole tip recession (PTR) software lets you easily and accurately measure individual sliders with less user oversight. With your samples mounted on a manual tilting stage, the automated process will measure each slider at the carrier, rowbar, or slider level.

Manual Tilting Stage



- **Tilting angle range**
+/- 3 degrees, 2.6 μm Z height change over 50 μm scan
- **Resolution**
45 nm Z height change per division on a rotation knob.

Ionization System for a more stable scanning environment

Our advanced ionization system quickly and effectively removes electrostatic charges in your sample's environment. Since the system always generates and maintains the ideal balance of positive and negative ions, it can create an extremely stable charge environment with little contamination of the surrounding area, and minimal risk of accidental electrostatic charge during sample handling.

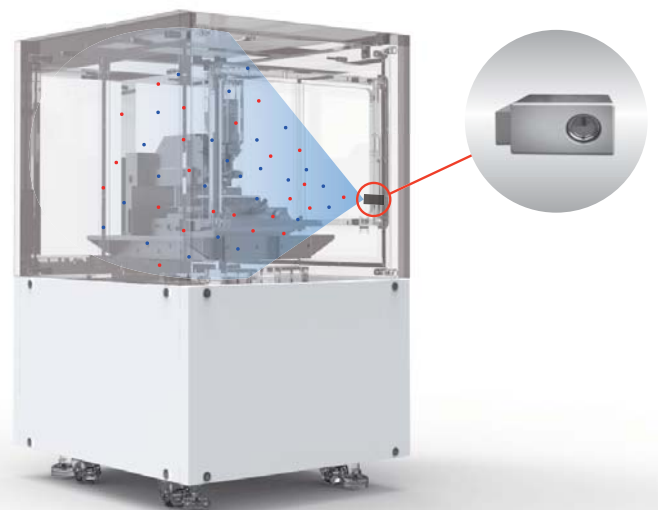

Park NX-HDM

Specification

System Specification	Motorized XY stage	Motorized Z stage	
	travels up to 150 mm × 150 mm, 2 μm repeatability	25 mm Z travel distance 0.1 μm resolution, <1 μm repeatability	
Scanner Performances	XY Scanner Range	XY Scanner Resolution	
	100 μm × 100 μm	0.095 nm (20 bit position control)	
AFM and XY Stage Control Electronics	ADC	DAC	
	18 channels 4 high-speed ADC channels (64 MSPS) 24-bit ADCs for X,Y and Z scanner position sensor	12 channels 2 high-speed DAC channels (64 MSPS) 20-bit DACs for X,Y and Z scanner positioning	
Vibration, Acoustic Noise	Floor Vibration		
	<0.5 μm/s (10 Hz to 200 Hz w/ Active Vibration Isolation System)		
Facility Requirements	Room Temperature (Stand By)	Room Temperature (Operating)	Humidity
	10 °C ~ 40 °C	18 °C ~ 24 °C	30% to 60% (not condensing)
Dimensions in mm & Weight in kg	Acoustic Enclosure	Control Cabinet	
	880 (w) × 980 (d) × 1460 (h) 620 kg approx. (incl. basic NX-HDM System)	600 (w) × 900 (d) × 1330 (h) 170 kg approx. (incl. controllers)	

Motorized Focus Stage	Sample Thickness Allowance	Z run-out	COGNEX Pattern Recognition
15 mm Z travel distance for on-axis optics	up to 20 mm	<2 nm over 80 μm	pattern align resolution of 1/4 pixel
Z Scanner Range	Z Scanner Resolution	Z Scanner Noise Floor	
15 μm	0.01 nm	<0.05 nm (w/ Active Vibration Isolation System)	

Acoustic Noise
 >20 dB attenuation w/ Acoustic Enclosure

Floor Vibration Level	Acoustic Noise	Pneumatics	Power Supply Rating	Total Power Consumption	Ground Resistance
VC-E (3 μm/sec)	Below 65 dB	Vacuum: -60 kPa	100/120 V/ 208~240 V, single phase, 15 A (max)	2 KW (typical)	Below 100 ohms

System Floor Space	Ceiling Height	Operator Working Space
1720 (w) × 920 (d)	2000 or more	2400 (w) × 2450 (d), minimum

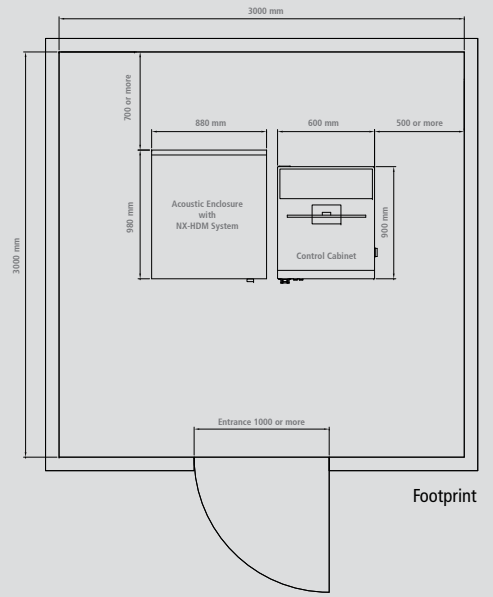
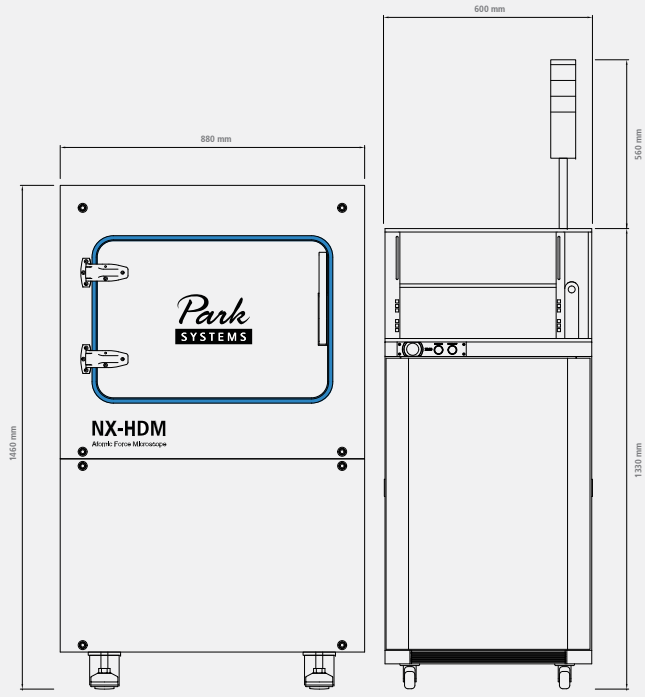

Park Systems

Dedicated to producing the most accurate and easiest to use AFMs

The global headquarters is located at
Korean Advanced Nanotechnology Center (KANC) in Suwon, Korea.



More than a quarter century ago, the foundations for Park Systems were laid at Stanford University where Dr. Sang-il Park, the founder of Park Systems worked as an integral part of the group that first developed AFM technology. After perfecting the technology, he then went on to create the first commercial AFM and later Park Systems was born.

Park Systems strives everyday to live up to the innovative spirit of its beginnings. Throughout our long history, we have honored our commitment to providing the most accurate and yet very easy to use AFMs, with revolutionary features like True Non-Contact™ mode, and many automated software tools. We are not simply content to rest on our past success. All of our products are designed with same care and creativity that went into our first, allowing you to focus on getting results without worrying about the integrity of your tools.

