

# R&S®FS-K85

## 1xEV-DO Mobilstationstest

### Software Manual



1300.6708.42 – 05

The Software Manual describes the following R&S®FS-K85:

- R&S®FMU
- R&S®FSG
- R&S®FSP
- R&S®FSQ
- R&S®FSUManual
- R&S®FSUP

© 2012 Rohde & Schwarz GmbH & Co. KG

81671 Munich, Germany

Printed in Germany – Subject to change – Data without tolerance limits is not binding.

R&S® is a registered trademark of Rohde & Schwarz GmbH & Co. KG.

Trade names are trademarks of the owners.

The following abbreviations are used throughout this manual:

R&S®FS-K85 is abbreviated as R&S FS-K85.

# Contents

<b>Documentation Overview</b> .....	<b>5</b>
<b>1xEV-DO Mobile Station Test Application Firmware R&amp;S FS-K85</b> .	<b>7</b>
<b>1 Installing and Enabling the Application Firmware</b> .....	<b>8</b>
1.1 Installation .....	8
1.2 Enabling.....	8
<b>2 Getting Started</b> .....	<b>9</b>
2.1 Generating a 1xEV-DO reverse link signal with WinIQSIM.....	10
2.2 Default settings in the 1xEV-DO MS operating mode .....	12
2.3 Measurement 1: Measurement of the signal power .....	13
2.4 Measurement 2: Measurement of the spectrum emission mask .....	14
2.5 Measurement 3: Measurement of the relative code domain power and frequency error.....	15
2.6 Setting: Synchronizing the reference frequencies.....	16
2.7 Setting: Behavior with deviating center frequency setting.....	16
2.8 Measurement 4: Triggered measurement of the relative code domain power....	17
2.9 Setting: Trigger offset .....	18
2.10 Measurement 5: Measurement of the composite EVM .....	19
2.11 Measurement 6: Measurement of the peak code domain error .....	20
2.12 Measurement 7: Measurement of the RHO factor .....	21
<b>3 Test Setup for Mobile Station Tests</b> .....	<b>22</b>
3.1 Standard-Test setup .....	22
3.2 Default settings .....	23
<b>4 Predefined Channel Tables</b> .....	<b>24</b>
<b>5 Menu Overview</b> .....	<b>25</b>
<b>6 Configuration of 1xEV-DO Measurements</b> .....	<b>28</b>
6.1 Measurement of channel power.....	28
6.2 Measurement of adjacent channel power - ACLR .....	30
6.3 Checking signal power - SPECTRUM EM MASK.....	38
6.4 Measurement of bandwidth occupied by signal - OCCUPIED BANDWIDTH .....	44

<b>6.5</b>	<b>Signal statistics.....</b>	<b>47</b>
<b>6.6</b>	<b>Code domain measurements on 1xEV-DO signals .....</b>	<b>51</b>
6.6.1	Presentation of evaluations - RESULTS.....	53
6.6.2	Configuration of measurements - Hotkey <i>CHAN CONF</i> .....	70
6.6.3	Configuration of the application firmware - Hotkey <i>SETTING</i> .....	75
6.6.4	Frequency settings - <i>FREQ</i> key.....	80
6.6.5	Span settings - <i>SPAN</i> key .....	80
6.6.6	Level settings - <i>AMPT</i> key .....	81
6.6.7	Marker settings - <i>MKR</i> key .....	82
6.6.8	Changing instrument settings - <i>MKR</i> → key.....	83
6.6.9	Marker functions - <i>MKR FCTN</i> key.....	84
6.6.10	Bandwidth setting - <i>BW</i> key.....	84
6.6.11	Measurement control - <i>SWEEP</i> key .....	84
6.6.12	Measurement selection - <i>MEAS</i> key.....	84
6.6.13	Trigger settings - <i>TRIG</i> key.....	84
6.6.14	Trace settings - <i>TRACE</i> key .....	85
6.6.15	Display lines - <i>LINES</i> key .....	86
6.6.16	Measurement screen settings - <i>DISP</i> key .....	86
6.6.17	Storing and loading instrument data - <i>FILE</i> key .....	86
6.6.18	Preset of device - <i>PRESET</i> key.....	87
6.6.19	Calibration of device - <i>CAL</i> key .....	87
6.6.20	Setup of device - <i>SETUP</i> key .....	87
6.6.21	Printing - <i>HCOPY</i> key .....	87
<b>7</b>	<b>Remote Control Commands .....</b>	<b>88</b>
7.1	<b>CALCulate:FEED subsystem.....</b>	<b>88</b>
7.2	<b>CALCulate:LIMit:SPECTrum Subsystem .....</b>	<b>90</b>
7.3	<b>CALCulate:MARKer - Subsystem.....</b>	<b>92</b>
7.4	<b>CALCulate:STATistics subsystem.....</b>	<b>94</b>
7.5	<b>CONFigure:CDPower subsystem.....</b>	<b>95</b>
7.6	<b>INSTrument Subsystem .....</b>	<b>102</b>
7.7	<b>SENSe:CDPower subsystem .....</b>	<b>103</b>
7.8	<b>TRACe Subsystem.....</b>	<b>113</b>
7.9	<b>STATus-QUEStionable:SYNC-Register .....</b>	<b>119</b>

<b>7.10</b>	<b>Table of softkeys with assignment of IEC/IEEE bus commands</b> .....	<b>121</b>
7.10.1	<i>MEAS</i> key or <i>MEAS</i> hotkey .....	121
7.10.2	<i>RESULTS</i> hotkey or <i>CODE DOM ANALYZER</i> softkey .....	124
7.10.3	<i>CHAN CONF</i> hotkey .....	125
7.10.4	<i>SETTINGS</i> hotkey .....	125
<b>8</b>	<b>Checking the Rated Specifications</b> .....	<b>127</b>
8.1	Measuring equipment and accessories .....	127
8.2	Test sequenceuf.....	128
<b>9</b>	<b>Code Table for Hadamard and BitReverse Order</b> .....	<b>130</b>
	<b>Glossary</b> .....	<b>131</b>
	<b>Index</b> .....	<b>132</b>



# Documentation Overview

The user documentation for the R&S FS-K85 is divided as follows:

- R&S®FMU
- R&S®FSG
- R&S®FSP
- R&S®FSQ
- R&S®FSU
- R&S®FSUP





# 1xEV-DO Mobile Station Test Application Firmware R&S FS-K85

When configured with the Application Firmware R&S FS-K85, the analyzer performs code domain power measurements on reverse link signals (mobile station) on the basis of the 3GPP2 Standard (Third Generation Partnership Project 2) "cdma2000 High Rate Packet Data". This standard, which was defined for packet-oriented data transmission, is generally referred to as 1xEV-DO (First Evolution Data Only). It is also referred to as such in the R&S FS-K85 application firmware.

In the standard, the term "Access Network" (AN) is used for the base station and the term "Access Terminal" (AT) for the mobile terminal. In order to retain a degree of similarity with the cdma2000 BTS and cdma2000 MS application firmware, the term referring to the mobile station is also used in the 1xEV-DO FS-K85 application firmware.

The 1xEV-DO BTS application firmware is based on the "**CDMA2000 High Rate Packet Data Air Interface Specification**" (version C.S0024 V3.0 from December 2001) and the "**Recommended Minimum Performance Standards for CDMA2000 High Rate Packet Data Access Terminal**" (version C.S0032-0 V1.0 from December 2001).

These standard documents are also published under TIA 856 (IS-856) and TIA 864 (IS-864). The application firmware supports the code domain measurements performed on 1xEV-DO reverse link signals. Examples of the evaluations provided by the code domain power analyzer are: code domain power, channel occupancy table, EVM, frequency error and RHO factor. All 5 channel types (PICH, RRI, DATA, ACK and DRC)<sup>1</sup> as well as TRAFFIC and ACCESS operating mode are supported. Owing to their time structure, the signals are analyzed on half-slot basis.

In addition to the code domain measurements, the application features measurements in the spectral range such as channel power, adjacent channel power, occupied bandwidth and spectrum emission mask with predefined settings.

---

<sup>1</sup> Abbreviations are explained in Chapter Glossary

# 1 Installing and Enabling the Application Firmware

## 1.1 Installation

If Application Firmware R&S FS-K85 has not been installed on the device, a firmware update will have to be performed. This has already been done in the case of installation at the factory.

Before the application firmware can be installed, corresponding basic firmware for the basic unit has to be installed on the analyzer. See the release notes of the current Application Firmware R&S FS-K85 for the compatible versions.

If the basic firmware has to be updated, start the update with the floppy disks containing the basic firmware by pressing *SETUP* → *NEXT* → *FIRMWARE UPDATE*.

When the correct basic software has been installed, the firmware update for the application can be started from the floppy disks containing the Firmware Application R&S FS-K85 by pressing the same keys: *SETUP* → *NEXT* → *FIRMWARE UPDATE*.

Following installation, the application firmware has to be enabled as described below.

## 1.2 Enabling

Application Firmware R&S FS-K85 is enabled in the *SETUP* → *GENERAL SETUP* menu by entering a keyword. The keyword comes with the application firmware. If the application firmware is installed at the factory, it will already be enabled.

### GENERAL SETUP Menu:

#### OPTIONS

The *OPTIONS* softkey opens a submenu in which you can enter the keywords for the application firmware. The existing applications are displayed in a table that opens when you enter the submenu.

#### INSTALL OPTION

The *INSTALL OPTION* softkey enables entry of the keyword for an application firmware.

One or more keywords can be entered in the entry field. If the keyword is valid, the message *OPTION KEY OK* is displayed and the application firmware is entered in the *FIRMWARE OPTIONS* table.

If an invalid keyword is entered, *OPTION KEY INVALID* is displayed.

If the version of the application firmware and that of the basic firmware are not compatible, you see a corresponding message. In this case, follow the instructions in the above chapter "Installation".

## 2 Getting Started

The following chapter explains basic 1xEV-DO mobile station tests using a test setup with the Signal Generator R&S SMIQ as the device under test. It describes how operating and measuring errors can be avoided by means of correct default settings.

The measurement screen is presented in Chapter 6 for the different measurements.

Attention is drawn to important settings exemplifying how to avoid measurement errors during measurements. The correct setting is followed by a demonstration of the effect of an incorrect setting. The following measurements are performed:

Measurement 1: Measurement of the signal spectrum

Measurement 2: Measurement of the spectrum emission mask

Measurement 3: Measurement of the relative code domain power and frequency error  
Setting: Center frequency

Measurement 4: Triggered measurement of the relative code domain power  
Setting: Trigger offset

Measurement 5: Measurement of the composite EVM

Measurement 6: Measurement of the peak code domain error

Measurement 7: Measurement of the RHO factor

The 1xEV-DO raw data is created with the R&S WinIQSIM software and loaded into the arbitrary waveform generator of the R&S SMIQ or R&S AMIQ.

Measurements are performed with the following instruments and accessories:

- Spectrum Analyzers R&S FSU, R&S FSP or Signal Analyzer R&S FSQ with Application Firmware R&S FS-K85 (mobile station test for 1xEV-DO).
- Vector Signal Generator R&S SMIQ with hardware options B11 (data generator) / B20 (modulation coder) and B60 (arbitrary waveform generator) plus firmware version 5.70 or higher with enabled option K17 1xEV-DO and R&S SMIQ-Z5 PARADATA BNC ADAPTER for an external trigger signal.
- PC that is either connected by means of a serial cable to the R&S SMIQ, or has an IEC/IEEE bus card and connected by means of an IEC/IEEE bus cable to the R&S SMIQ. WinIQSIM software V3.91 or higher must be installed on the PC. The software can be downloaded from the Rohde & Schwarz web site on the Internet at <http://www.rohde-schwarz.com>.
- One coaxial cable, 50  $\Omega$ , approximately 1 m, N connector
- Two coaxial cables, 50  $\Omega$ , approximately 1 m, BNC connector

## 2.1 Generating a 1xEV-DO reverse link signal with WinIQSIM

You can download the WinIQSIM Software from <http://www.rohde-schwarz.com> and install it on a PC. The WinIQSIM software can be used to generate 1xEV-DO reverse link signals, which are then transferred on an R&S SMIQ or R&S AMIQ. An explanation is given below of how the test signal is generated. WinIQSIM Version 3.91 or higher is required.

1. Start and select standard:
  - a. Start **WinIQSIM.exe**.
  - b. In the **File** menu, select the **New** option and select **1XEV-DO** from the list that follows. The 1XEV-DO dialog box appears.
  - c. Under General Settings, first select **Uplink/Reverse Link** to switch to the mobile station signals. Activate **MS1** by clicking **ON** and then click **MS1** to configure mobile station 1.

The dialog box looks like the one below:

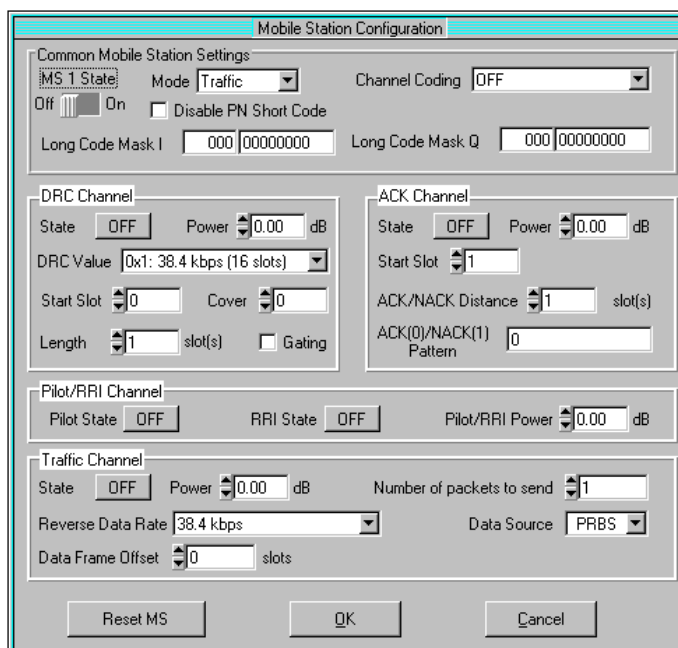

*Fig. 1 WinIQSIM prior to defining the active channels*

2. Activate channels:

In this **mobile station configuration**, the following settings are performed so that a reverse link signal with all channels is generated.

- a. **DRC Channel:** Set State to ON, Power to -3 dB and DRC Value to 0x6: 614.4 kbps (1 slots).
- b. **ACK Channel:** Set State to ON, Power to -7 dB, Start Slot to 6, ACK/NACK Distance to 3 and Pattern to 1110.
- c. **Pilot/RRI Channel:** Set Pilot State to ON and RRI State to ON.
- d. **Traffic Channel:** Set State to ON and Power to -7 dB.

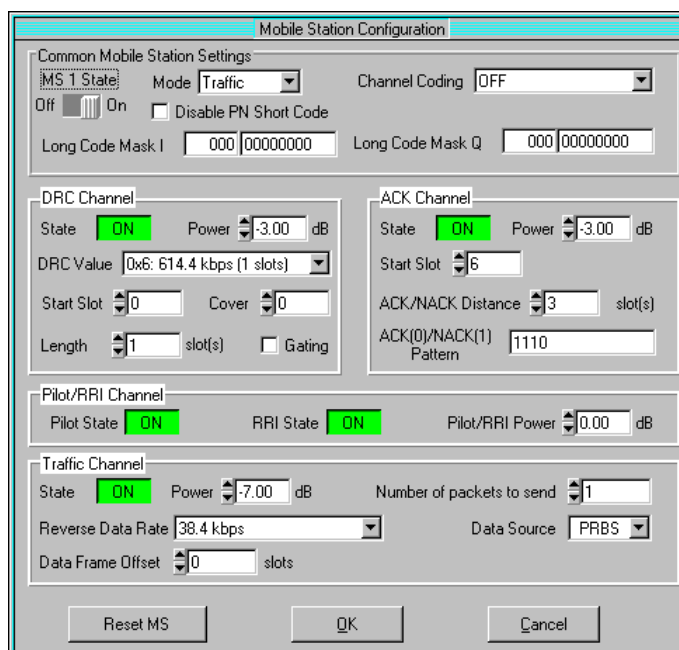

Fig. 2 WinIQSIM configuration with active channels

3. Define trigger settings:

Now you have to set the trigger settings in the **SMIQ** menu, item **Trigger Output Settings**. **Restart Clock (SEQUENZ)** is defined for **Current Mode: Mode 1**. This means that the trigger at the slot limit is available every 80 ms at TRIG1 of the R&S SMIQ Z5 BNC adapters.

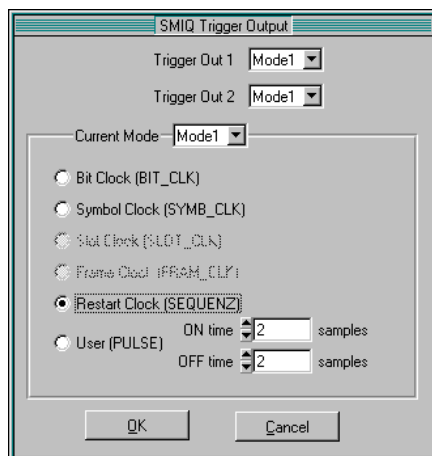

Fig. 3 WinIQSIM base station configuration of the finished model

4. Save and transfer to R&S SMIQ:

- a. Save this 1xEV-DO configuration with **File|Save** as file 'DOMS.IQS'.
- b. Connect the R&S SMIQ either serially or by means of an IEC/IEEE bus card and IEC/IEEE bus cable, and load the generated signal to the R&S SMIQ under the name 'DOMS' in the **SMIQ|TRANSMISSION** menu.

## 2.2 Default settings in the 1xEV-DO MS operating mode

In the default setting after PRESET, the analyzer is in spectrum mode. The following default settings of the code domain measurement are not activated until you select the 1xEV-DO MS operating mode with the 1xEVDO MS hotkey.

**Table 1 Default settings of code domain measurement after preset**

Parameter	Setting
Digital standard	CDMA 2000 MC1 (MC1 stands for Multi-Carrier 1 and thus describes cdma2000 1X, i.e. a single carrier)
Band class	Band class 0 (800 MHz band)
Sweep	CONTINUOUS
CDP mode	CODE CHAN AUTOSEARCH
Trigger setting	FREE RUN
Triggeroffset	0 s
Long code mask I	0
Long code mask Q	0
Threshold value	-40 dB
SELECT I/Q	I (the I branch is evaluated)
Code number	0
Half-slot number	0
Capture length	6 half slots (one half slot contains 1024 chips and lasts 0.833 ms)
Code order	Hadamard
Operation	Traffic
CDP average	OFF
Evaluation	Screen A: CODE PWR RELATIVE Screen B: RESULT SUMMARY

- The following conventions apply to the presentation of settings on the analyzer:
  - [<Key>]** Press a key on the front panel, e.g. [SPAN].
  - [<SOFTKEY>]** Press a softkey, e.g. [MARKER -> PEAK].
  - [<nn unit>]** Enter a value and terminate with the unit, e.g. [12 kHz].
- The following conventions apply to the presentation of settings on the R&S SMIQ:
  - [<Key>]** Press a key on the front panel, e.g. [FREQ].
  - <MENU>** Choose a menu, parameter or setting, e.g. DIGITAL STD. The menu level is identified by indenting.
  - <nn unit>** Enter a value and terminate with the unit, e.g. 12 kHz.

## 2.3 Measurement 1: Measurement of the signal power

Measurement of the spectrum provides an overview of the 1xEV-DO signal and the carrier-oriented spurious emissions.

### Test setup

- ▶ Connect the RF output of the R&S SMIQ to the RF input of the analyzer (coaxial cable with N connectors).

### Settings on R&S SMIQ:

#### [PRESET]

[LEVEL: 0 dBm]

[FREQ: 833.49 MHz]

ARB MOD

SET SMIQ ACCORDING TO WAVEFORM ...

SET SMIQ ACCORDING TO WAVEFORM ON

IQ SWAP (VECTOR MODE) ON

TRIGGER OUT MODE ON

(These 3 settings are only needed once after presetting the generator and are used to apply, in VECTOR MODE, the IQ SWAP and, in ARB MOD, the trigger setting automatically from the waveform file generated by WinIQSIM. This is especially convenient when changing between different waveforms.

SELECT WAVEFORM... select name 'DOMS

STATE: ON

### Settings on analyzer:

[PRESET]

[FREQUENCY: 833.49 MHz]

[AMPT: 0 dBm]

[1xEVDO MS]

[MEAS: POWER]

### Measurement on analyzer:

The following is displayed:

- The spectrum of the 1xEV-DO signal
- The channel power of the signal within the 1.2288 MHz channel bandwidth

## 2.4 Measurement 2: Measurement of the spectrum emission mask

The 1xEV-DO specification calls for a measurement which monitors compliance with a spectral mask in a range of at least  $\pm 4.0$  MHz around the 1xEV-DO carrier. To assess the power emissions within the specified range, the signal power is measured with a 30 kHz filter. The resulting trace is compared with the limit line, defined in the 1xEV-DO specification, according to the selected band class.

### Test setup

- ▶ Connect the RF output of the R&S SMIQ to the RF input of the analyzer (coaxial cable with N connectors).

### Settings on R&S SMIQ:

R&S SMIQ settings as for measurement 1.

### Settings on analyzer:

```
[PRESET]      Band class 0 is thus selected  
[FREQUENCY:  833.49 MHz]  
[AMPT:       0 dBm]  
[1xEVDO MS]  
[MEAS:      SPECTRUM EM MASK]
```

### Measurement on analyzer:

The following is displayed:

- The spectrum of the 1xEV-DO signal
- The limit line defined in the standard
- Information on limit line overranging (passed/failed)
- If available, the largest overrange with frequency and level value



## 2.5 Measurement 3: Measurement of the relative code domain power and frequency error

Measurement of the code domain power on a test model (with 3 channels) is shown below. The basic parameters of the CDP measurements, which allow analysis of the signal, are changed one after another from values adapted to the test signal to non-adapted values to demonstrate the resulting effects.

### Settings on R&S SMIQ:

- ▶ Connect the RF output of the SMIQ to the RF input of the analyzer.
- ▶ Connect the reference input (EXT REF IN / OUT) on the rear panel of the analyzer to the reference output (REF) on the SMIQ (coaxial cable with BNC connectors).

### Settings on R&S SMIQ:

SMIQ settings as for measurement 1.

### Settings on analyzer:

**[PRESET]**  
**[FREQUENCY: 833.49 MHz]**  
**[AMPT: 10 dBm]**  
**[1xEVDO MS]**

### Measurement on analyzer:

The following is displayed:

Screen A: Code domain power of the signal (model with 3 channels)

Screen B: Numerical results of CDP measurement including the frequency error

## 2.6 Setting: Synchronizing the reference frequencies

Synchronizing the transmitter and receiver to the same reference frequency reduces the frequency error.

### Test setup

- ▶ Connect the reference input (EXT REF IN / OUT) on the rear panel of the analyzer to the reference output (REF) on the rear of the SMIQ (coaxial cable with BNC connectors).

### Settings on R&S SMIQ:

As for measurement 1

### Settings on analyzer:

As for measurement 3, plus

[SETUP: REFERENCE EXT]

### Measurement on analyzer:

Screen B: Frequency error: The indicated frequency error should be < 10 Hz.

**The reference frequencies of the analyzer and the device under test should be synchronized.**

## 2.7 Setting: Behavior with deviating center frequency setting

In the following setting, the behavior of the device under test and analyzer with a deviating center frequency setting is shown.

### Settings on R&S SMIQ:

- ▶ Tune the center frequency of the signal generator in 0.1 kHz steps and watch the analyzer screen.

### Measurement on analyzer:

- CDP measurement is still possible on the analyzer up to a frequency error of about 4.0 kHz. A difference in the measurement accuracy of the CDP measurement is not discernible up to this frequency error.
- The probability of impaired synchronization increases from a frequency offset of 4.3 kHz and higher. The 'Sync Failed' message appears.

### Settings on R&S SMIQ:

- ▶ Set the signal generator center frequency again to 833.49 MHz  
[FREQ: 833.49 MHz]

**The center frequency of the analyzer must correspond to the frequency of the device under test to within a 4.0 kHz offset.**

## 2.8 Measurement 4: Triggered measurement of the relative code domain power

If code domain power measurement is performed without external triggering, an extract is recorded from the test signal at a random point in time and an attempt is made to detect the start of a slot in it. To detect this start, all possibilities of the PN sequence location have to be tested in Free Run mode. This requires computing time. This computing time can be reduced by creating an external (frame) trigger. The search range for the start of the power control group are known and fewer options have to be tested.

### Test setup

- ▶ Connect the RF output of the R&S SMIQ to the RF input of the analyzer.
- ▶ Connect the reference frequencies (see measurement 2).
- ▶ Connect the external triggering of the analyzer (EXT TRIG GATE) to the R&S SMIQ trigger (TRIGOUT1 to PARADATA).

### Settings on R&S SMIQ:

As for measurement 1

### Settings on analyzer:

As for measurement 3, plus  
**[TRIG: EXTERN]**

### Measurement on analyzer:

The following is displayed:

Screen A: Code domain power of the signal

Screen B: Numerical results of CDP measurement

Trg to Frame: Timing offset between trigger event and start of the slot

The repetition rate of the measurement increases compared with measurement without an external trigger.

## 2.9 Setting: Trigger offset

Any delay of the trigger event compared to the start of the half slot can be compensated by changing the trigger offset.

### Settings on analyzer:

As for measurement 3, plus

**[TRIG:]**

[TRIG OFFSET 100  $\mu$ s]

### Measurement on analyzer:

The parameter "Trg to Frame" in the numerical results table (Screen B) changes:

*Trg to Frame* -100  $\mu$ s

<b>A trigger offset compensates analog delays of the trigger event.</b>
---

## 2.10 Measurement 5: Measurement of the composite EVM

Composite EVM is the measurement of the mean square error of the total signal, as defined in the 1xEV-DO specification.

An ideal reference signal is generated from the demodulated data. The test signal and the reference signal are compared with each other; the square deviation produces the Composite EVM measurement.

### Test setup

- ▶ Connect the RF output of the R&S SMIQ to the RF input of the analyzer (coaxial cable with N connectors).
- ▶ Connect the reference input (EXT REF IN / OUT) on the rear panel of the analyzer to the reference output (REF) on the R&S SMIQ (coaxial cable with BNC connectors).
- ▶ Connect the external triggering of the analyzer (EXT TRIG GATE) to the R&S SMIQ trigger (TRIGOUT1 to PARADATA).

### Settings on R&S SMIQ:

R&S SMIQ settings as for measurement 1.

### Settings on analyzer:

```
[PRESET]
[FREQUENCY: 833.49 MHz]
[AMPT: 10 dBm]
[1xEVDO MS]
[TRIG EXTERN]
[RESULTS COMPOSITE EVM]
```

### Measurement on analyzer:

The following is displayed:

Screen A: Code domain power of the signal

Screen B: Composite EVM (EVM for total signal)

## 2.11 Measurement 6: Measurement of the peak code domain error

With the peak code domain error measurement, an ideal reference signal is generated from the demodulated data. The test signal and the reference signal are compared with each other; the difference between the two signals is projected to the class of the base spreading factor. The peak code domain error measurement is obtained by summing the symbols of each difference signal half slot and searching for the maximum error code.

### Test setup

- ▶ Connect the RF output of the R&S SMIQ to the RF input of the analyzer (coaxial cable with N connectors).
- ▶ Connect the reference input (EXT REF IN / OUT) on the rear panel of the analyzer to the reference output (REF) on the R&S SMIQ (coaxial cable with BNC connectors).

### Settings on R&S SMIQ:

R&S SMIQ settings as for measurement 1.

### Settings on analyzer:

**[PRESET]**

*[FREQUENCY: 833.49 MHz]*

*[AMPT: 0 dBm]*

*[1xEVDO MS]*

*[RESULTS PEAK CODE DOMAIN ERR]*

### Settings on analyzer:

The following is displayed:

Screen A: Code domain power of the signal

Screen B: Peak code domain error (for base spreading factor with default value 64)

## 2.12 Measurement 7: Measurement of the RHO factor

Measurement of the RHO factor is shown below. The RHO quality parameter should be measured using a signal which only contains the pilot channel. Accordingly, only the pilot has to be activated in a WinIQSIM model.

### Settings on R&S SMIQ:

- ▶ Connect the RF output of the R&S SMIQ to the RF input of the analyzer.
- ▶ Connect the reference input (EXT REF IN / OUT) on the rear panel of the analyzer to the reference output (REF) on the R&S SMIQ (coaxial cable with BNC connectors).

### Settings on R&S SMIQ:

R&S SMIQ settings as for measurement 1, but only the pilot has to be activated in the WinIQSIM model.

### Settings on analyzer:

**[PRESET]**  
*[FREQUENCY: 833.49 MHz]*  
*[AMPT: 10 dBm]*  
*[1xEVDO MS]*

### Measurement on analyzer:

The following is displayed:

Screen A: Code domain power of the signal (I branch)

Screen B: Numerical results of CDP measurement including the RHO factor

## 3 Test Setup for Mobile Station Tests

### NOTICE

#### Instrument damage caused by disregarding the following precautions!

Any non-compliance with the following precautions may cause damage to the instrument. Prior to putting the instrument into operation, check the following:

- The covers of the housing are in place and screwed on.
- Vents are not obstructed. Make sure that the air can escape freely through the vents at the sides. The minimum distance to the wall should therefore be at least 10 cm.
- The signal levels at the inputs do not exceed permissible limits.
- The outputs of the instrument are not overloaded or incorrectly connected. This particularly applies to the maximum permissible back-feed at the outputs, which is specified in the data sheet
- The ambient temperature must not exceed the range specified in the data sheet.

This chapter describes the default settings of the analyzer for operation as a 1xEV-DO mobile station tester. A condition that has to be met before measurements can start is that the analyzer is correctly configured and supplied with power, as described in Chapter 1 of the operating manual for the basic unit. Furthermore, Application Firmware R&S FS-K85 must be enabled. Chapter 1 of this manual describes how to install and enable the application firmware.

### 3.1 Standard-Test setup

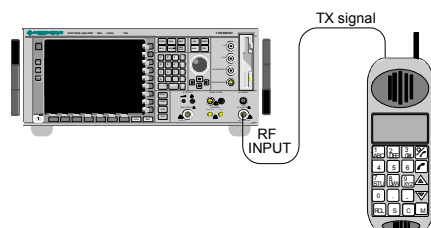

Fig. 4 MS test setup

- ▶ Connect the antenna output (or TX output) of the mobile station to the RF input of the analyzer by means of a power attenuator exhibiting suitable attenuation. The following level values for external attenuation are recommended to ensure that the RF input of the analyzer is protected and the sensitivity of the instrument is not impaired too much:



Max. power	Recommended external attenuation
≥ 55 to 60 dBm	35 to 40 dB
≥ 50 to 55 dBm	30 to 35 dB
≥ 45 to 50 dBm	25 to 30 dB
≥ 40 to 45 dBm	20 to 25 dB
≥ 35 to 40 dBm	15 to 20 dB
≥ 30 to 35 dBm	10 to 15 dB
≥ 25 to 30 dBm	5 to 10 dB
≥ 20 to 25 dBm	0 to 5 dB
< 20 dBm	0 dB

- ▶ For signal measurements at the output of two-port networks, connect the reference frequency of the signal source to the rear reference input of the analyzer (*EXT REF IN / OUT*).
- ▶ To maintain the error limits called for in the 1xEV-DO specification during frequency measurement on mobile stations, the analyzer has to be operated on an external reference. A rubidium frequency standard is a possible reference source.
- ▶ If the mobile station has a trigger output, connect the trigger output of the mobile station to the rear trigger input of the analyzer (*EXT TRIG GATE*).

## 3.2 Default settings

- ▶ Enter the external attenuation. **[AMPT] [NEXT] [REF LVL OFFSET].**
- ▶ Enter the reference level. **[AMPT]**
- ▶ Enter the center frequency. **[FREQUENCY]**
- ▶ Set the trigger. **[TRIG]**
- ▶ If used, switch on the external reference. **[SETUP] [REF: EXT]**
- ▶ Select the standard and the required measurement. **[1xEVDO MS] [RESULTS]**

## 4 Predefined Channel Tables

By default, the application firmware works in the Automatic Channel Search mode (softkey *CODE CHAN AUTOSEARCH*). However, there is also the option of using predefined channel tables and taking the code domain analysis as a basis. To do this, select the channel table and enable the predefined search mode (softkey *CODE CHAN PREDEFINED*). In accordance with the 1xEV-DO specification, different channel tables are defined for the various operating modes. These tables are listed below. Should channels other than those that appear in the predefined channel tables of the firmware application be used, the original tables should be copied and the channels adapted in the copy. (See the *CHAN CONF* hotkey on page 70.)

The activity for each half slot indicates whether the channel concerned is active (1) or inactive (0) in the half slot.

Channel table with the pilot channel (with the name **PICH**) as it exists in Access mode at least during the first slot 16.

*Table 2 Channel table with pilot*

Channel type	Code channel (Walsh Code.SF)	Mapping	Activity
PICH	0.16	I	1111 1111 1111 1111

Channel table with pilot channel and RRI with the name **PICHRRI**. The channels are active on the same code but at different times.

If the RRI and the PICH are active, it is assumed that for the first 256 chips (1/4 of the half slot, 1/8 of the entire slot) only the RRI and then the PICH is active in this half slot. If only the PICH is active (RRI activity 0), the PICH is active for the entire 1024 chips of the half slot.

*Table 3 Channel table with Pilot and RRI*

Channel type	Code channel (Walsh Code.SF)	Mapping	Activity
PICH	0.16	I	1111 1111 1111 1111
RRI	0.16	I	1010 1010 1010 1010

Channel table with **5** channels: PICH/RRI/DRC/ACK/DATA **5CHANS**.

*Table 4 Channel table for 5 channels with the name 5CHANS*

Channel type	Code channel (Walsh Code.SF)	Mapping	Activity
PICH	0.16	I	1111 1111 1111 1111
RRI	0.16	I	1010 1010 1010 1010
DATA	2.4	Q	1111 1111 1111 1111
ACK	4.8	I	0000 0000 0000 1000
DRC	8.16	Q	0110 0000 0000 0000

For further information on the channel table defaults, see hotkey *CHAN CONF*. The channel abbreviations are defined in Chapter Glossary

# 5 Menu Overview

Application Firmware R&S FS-K85 (1xEV-DO mobile station tests) enables the analyzer to perform RF measurements and code domain power measurements for the 1xEV-DO Reverse Link mobile radio standard.

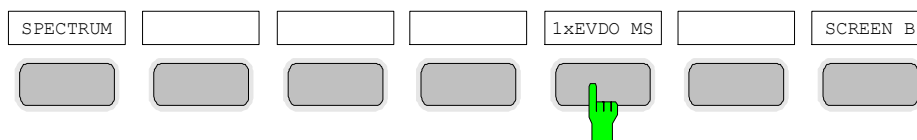

Fig. 5 Hotkey bar with enabled Application Firmware R&S FS-K85

After the application firmware has been called by pressing hotkey 1xEVDO MS, a new hotkey bar is displayed at the bottom edge of the screen and the code domain analyzer is selected and started.

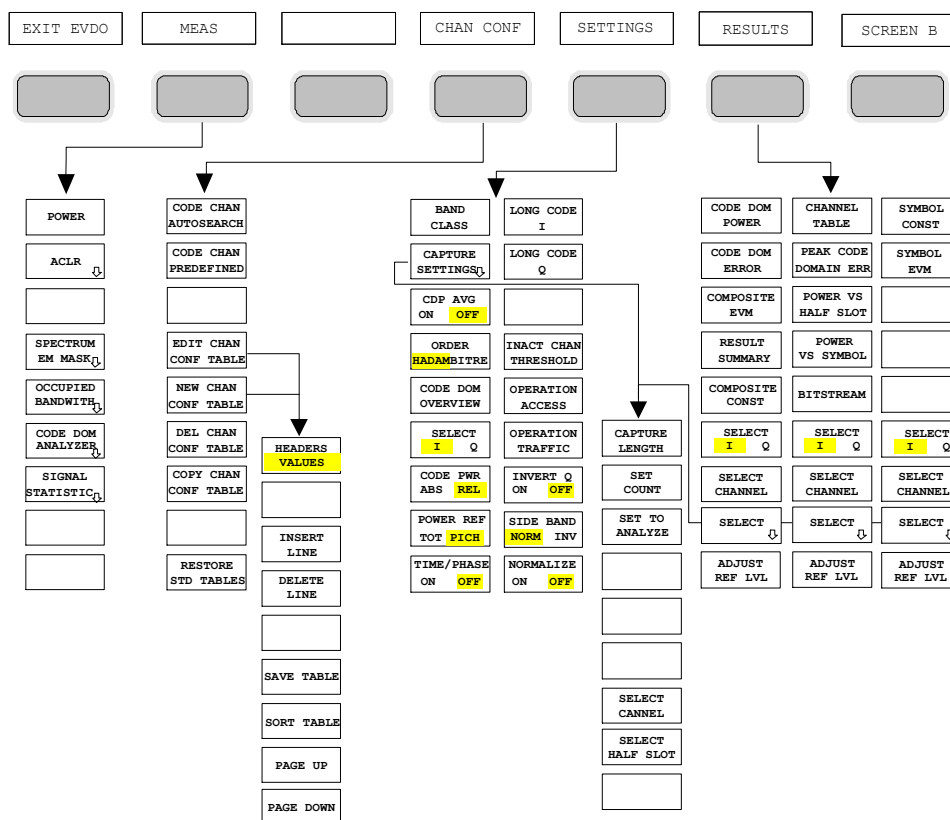

Fig. 6 Overview of menus in Application Firmware R&S FS-K85

The code domain analyzer can produce different kinds of results. These can be selected by means of the RESULTS hotkey. The SETTINGS hotkey can be used to configure the application firmware. The capture length or the band class can be set in this menu, for example. The CHAN CONF hotkey sets the channel search mode for the code domain analyzer. Users can also define their own channel tables.

The MEAS hotkey is identical to the MEAS key (right on the front panel) and is used to select the different RF measurements or the code domain analyzer.

Selecting the *CHAN CONF* or *RESULTS* hotkey automatically switches to the code domain analyzer.

Pressing the *EXIT EVDO* hotkey exits from R&S FS-K85. The hotkey bar of the basic unit appears again and the analyzer goes into the default *SPECTRUM* mode.

#### **Change from SPECTRUM mode to application firmware:**

The following user-specific settings are not modified so that the adaptation to the device under test is preserved:

- Reference Level + Rev Level Offset
- Center Frequency + Frequency Offset
- Input Attenuation + Mixer Level

The following user-specific settings are adopted as follows:

- External trigger sources are preserved, while all other trigger sources result in FREE RUN mode.
- Additional trigger settings are preserved.

#### **Change from application firmware to SPECTRUM mode:**

The following user-specific settings are not modified so that the adaptation to the device under test is preserved:

- Reference Level + Rev Level Offset
- Center Frequency + Frequency Offset
- Input Attenuation + Mixer Level

The following user-specific settings are adopted as follows:

- The trigger source is switched to *FREE RUN* and an analyzer frequency sweep is set with the SPAN equal to double the center frequency, or the maximum possible span, so that the center frequency always remains unchanged.

The measurements available in R&S FS-K85 can be selected by means of the MEAS hotkey or the MEAS key:

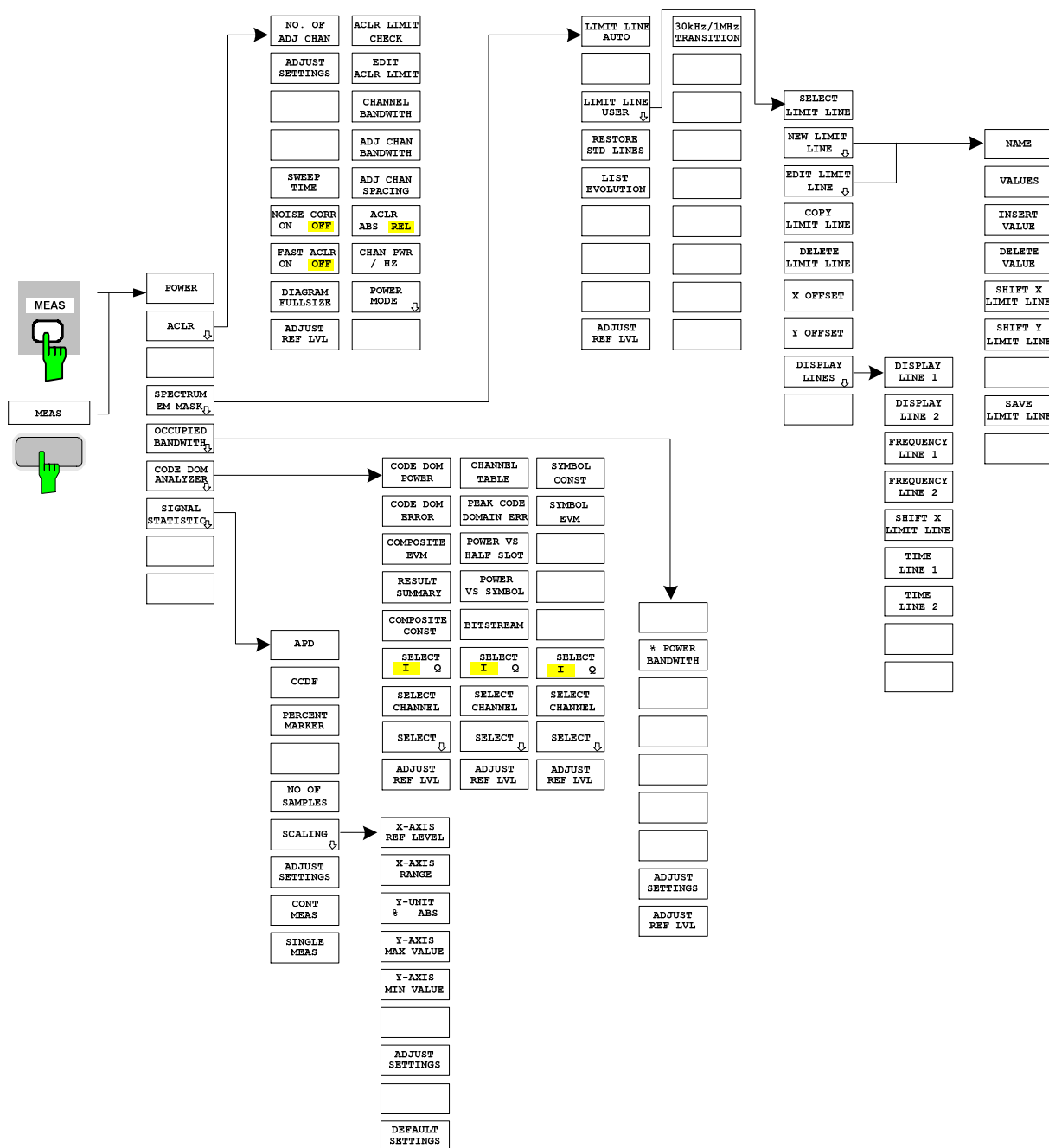

Fig. 7 Overview of menus

## 6 Configuration of 1xEV-DO Measurements

The most important measurements of the 1xEV-DO specification for mobile stations can be selected by means of the *MEAS* hotkey and *MEAS* key. They are explained below with reference to the softkey functions.

The *CODE DOM ANALYZER* softkey activates the code domain analyzer and takes you to the submenus for selecting the results. Changing the assignment of the hotkey bar when switching over to the application ensures that the most important parameters of the code domain analyzer can be directly accessed on the hotkey bar.

The softkeys *POWER*, *ACLR*, *SPECTRUM EM MASK*, *OCCUPIED BANDWIDTH*, and *STATISTICS* enable mobile station measurements with predefined settings, which are performed in *SPECTRUM* mode of the basic unit. The measurements are performed with the parameters contained in the 1xEV-DO specification. Subsequent alteration of the settings is possible.

### **MEAS key or MEAS hotkeys**

The *MEAS* hotkey or the *MEAS* key opens a submenu for selecting measurements:

- *POWER* activates channel power measurement with defined defaults in *SPECTRUM* mode.
- *ACLR* activates adjacent channel power measurement with defined defaults in *SPECTRUM* mode.
- *SPECTRUM EM MASK* compares the signal power in different offset ranges of the carrier with the maximum values laid down in the 1xEV-DO specification.
- *OCCUPIED BANDWIDTH* activates measurement of the bandwidth occupied by the signal.
- *CODE DOM ANALYZER* activates the code domain analyzer and opens another menu for choosing the results. All other menus of the analyzer are adapted to the functions of the code domain analyzer mode. The code domain analyzer is described in a separate chapter starting on page 51.
- *STATISTICS* evaluates the signal with regard to its statistical characteristics (distribution function of the signal amplitudes).

### 6.1 Measurement of channel power

#### **POWER**

The *POWER* softkey enables measurement of the channel power of the 1xEV-DO signal.

The analyzer measures the RF signal power in the 1.2288 MHz bandwidth. The power is calculated by summation of the values at the trace points. The bandwidth and the associated channel power are displayed beneath the measurement screen.

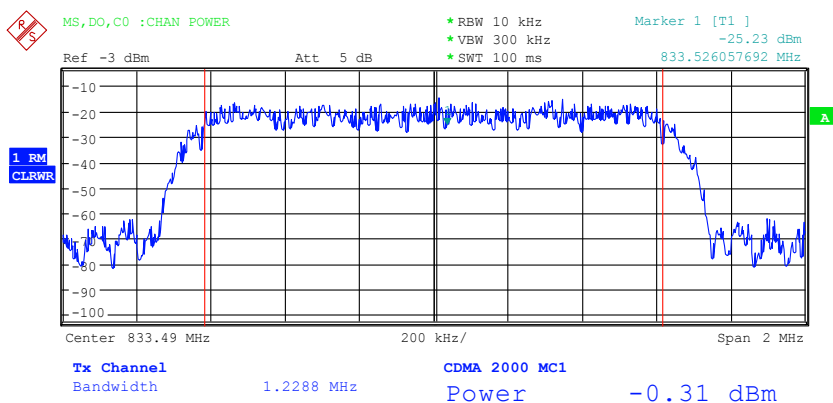

Fig. 8 Power measurement in the 1.2288 MHz transmission channel

The softkey activates *SPECTRUM* mode with defined settings:

The following user-specific settings are not modified on the first access following presetting

Level parameters  
Center Frequency + Frequency Offset  
All trigger settings

ADJACENT CHAN POWER	ON
ACP STANDARD	cdma2000 MC1 (MC1 stands for Multi-Carrier 1, i.e. a single carrier)
NO OF ADJ CHANNELS	0 (main channel only)
FREQUENCY SPAN	2 MHz

Departing from these settings, the analyzer can be operated in all functions featured in *SPECTRUM* mode, i.e. all measurement parameters can be adapted to the requirements of the specific measurement.

To restore adapted measurement parameters, the following parameters are saved on exiting and are set again on re-entering this measurement:

Level parameters  
RBW, VBW  
Sweep time

Remote: CONF:CDP:MEAS POW  
Query of results: CALC:MARK:FUNC:POW:RE? CPOW

## 6.2 Measurement of adjacent channel power - ACLR

### Softkey ACLR

MEAS key or MEAS hotkey

<a href="#">NO. OF ADJ CHAN</a>
<a href="#">ADJUST SETTINGS</a>
<a href="#">NOISE CORR ON/OFF</a>
<a href="#">FAST ACLR</a>
<a href="#">DIAGRAM FULL SIZE</a>
<a href="#">ADJUST REF LVL</a>
<a href="#">ACLR LIMIT CHECK</a>
<a href="#">CHANNEL BANDWIDTH</a>
<a href="#">ADJ CHAN BANDWIDTH</a>
<a href="#">ADJ CHAN SPACING</a>
<a href="#">ACLR ABS/REL</a>
<a href="#">CHAN PWR / HZ</a>
<a href="#">POWER MODE</a>

The *ACLR* softkey (adjacent channel leakage power ratio) activates measurement of adjacent channel power. The settings and limit values are taken from the spurious measurement defined in the 1xEV-DO specification.

The analyzer measures the power of the useful channel and of the adjacent channels on the left and right sides. In the default setting, only two adjacent channels are considered. Measurement results are displayed beneath the measurement screen.

The limits depend on the band class setting (*BAND CLASS* softkey).

The *ACLR* limit check can be enabled or disabled by means of the *ACLR LIMIT CHECK* softkey.

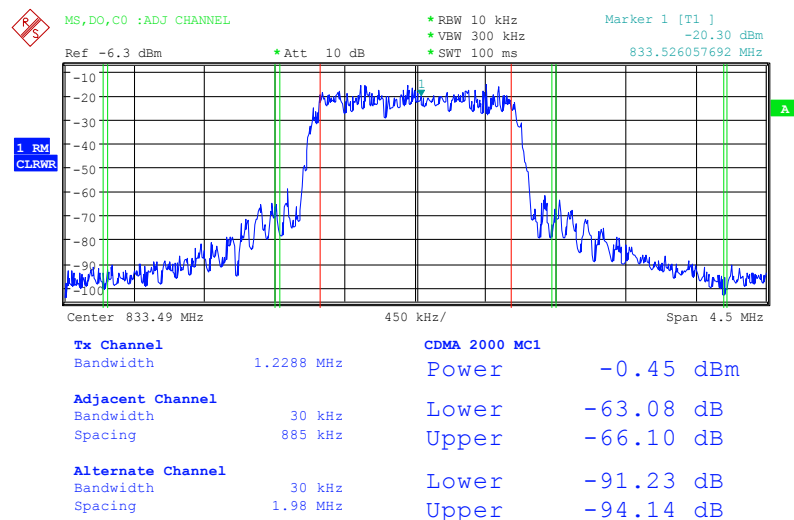

**Fig. 9** Measurement of adjacent channel power

The softkey activates *SPECTRUM* mode with defined settings:

The following user-specific settings are not modified on the first access following presetting:
Level parameters
Center Frequency + Frequency Offset



All trigger settings	
ADJACENT CHAN POWER	ON
ACP STANDARD	cdma2000 MC1
NO OF ADJ. CHANNELS	2

**Table 5 ACLR settings for band classes 0, 2, 5, 9, 11 and 12**

Adjacent channel type	Spacing	RBW	Rel. Limit	Abs. Limit
Adjacent	885 kHz	30 kHz	-42 dBc	-70.2 dBm
Alternate	1.98 MHz	30 kHz	-54 dBc	-70.2 dBm
Alternate2	4.00 MHz	30 kHz	-54 dBc	-70.2 dBm

**Table 6 ACLR Einstellungen für Band Klasse 3**

Adjacent channel type	Spacing	RBW	Rel. Limit	Abs. Limit
Adjacent	885 kHz	30 kHz	-42 dBc	-70.2 dBm
Alternate	1.98 MHz	30 kHz	-54 dBc	-70.2 dBm
Alternate2	4.00 MHz	30 kHz	-54 dBc	none

**Table 7 ACLR settings for band class 7**

Adjacent channel type	Spacing	RBW	Rel. Limit	Abs. Limit
Adjacent	885 kHz	30 kHz	-42 dBc	-70.2 dBm
Alternate	1.98 MHz	30 kHz	-42 dBc	-70.2 dBm
Alternate2	2.25 MHz	30 kHz	none	-28.2 dBm

**Table 8 ACLR settings for band class 10**

Adjacent channel type	Spacing	RBW	Rel. Limit	Abs. Limit
Adjacent	885 kHz	30 kHz	-42 dBc	-70.2 dBm
Alternate	1.25 MHz	30 kHz	none	-13 dBm
Alternate2	4.00 MHz	30 kHz	none	-13 dBm

**Table 9 ACLR settings for band class 1, 4, 8, 14 und 15**

Adjacent channel type	Spacing	RBW	Rel. Limit	Abs. Limit
Adjacent	1.25 MHz	30 kHz	-42 dBc	-70.2 dBm
Alternate	1.98 MHz	30 kHz	-50 dBc	-70.2 dBm
Alternate2	4.00 MHz	30 kHz	-50 dBc	-70.2 dBm

**Table 10 ACLR settings for band class 6**

Adjacent channel type	Spacing	RBW	Rel. Limit	Abs. Limit
Adjacent	1.25 MHz	30 kHz	-42 dBc	-70.2 dBm
Alternate	1.98 MHz	30 kHz	-50 dBc	-70.2 dBm
Alternate2	2.25 MHz	30 kHz	none	-28.3 dBm



The limit is corrected by  $0 \log \text{RBW} - 10 \log 30 \text{ kHz}$  for limit values which are not specified for 30 kHz bandwidth in the standard.

To restore adapted measurement parameters, the following parameters are saved on exiting and are set again on re-entering this measurement:

Level parameters  
 RBW, VBW  
 Sweep time  
 SPAN  
 NO OF ADJ. CHANNELS  
 FAST ACLR MODUS

Departing from these settings, the analyzer can be operated in all functions featured in SPECTRUM mode, i.e. all measurement parameters can be adapted to the requirements of the specific measurement.

Remote: CONF:CDP:MEAS ACLR

Query of results: CALC:MARK:FUNC:POW:RES? ACP

#### NO. OF ADJ CHAN

The *NO. OF ADJ CHAN* softkey activates input of the number  $\pm n$  of adjacent channels which are taken into account for the adjacent channel power measurement.

A number between 0 and 12 can be entered.

The following measurements are performed depending on the number of channels.

- 0 Only the channel power is measured.
- 1 The channel power and the power of the upper and lower adjacent channel are measured.
- 2 The channel power, the power of the upper and lower adjacent channel and of the next upper and lower channel (alternate channel 1) are measured.
- 3 The channel power, the power of the upper and lower adjacent channel, the next higher and lower channel (alternate channel 1) and the next but one higher and lower channel (alternate channel 2) are measured.

With higher numbers the procedure is expanded accordingly.

Remote: SENS:POW:ACH:ACP 2

#### ADJUST SETTINGS

The *ADJUST SETTINGS* softkey automatically optimizes analyzer settings for the selected power measurement. All analyzer settings relevant for power measurements within a specific frequency range (channel bandwidth) are optimally set depending on the channel configuration (channel bandwidth, channel spacing).

- Frequency span:
  - The frequency span must include at least the channels to be analyzed.
  - When channel power is measured, the span is set to double the channel bandwidth.
  - The span setting for adjacent channel power measurement depends on the channel spacing and channel bandwidth of the adjacent channel ADJ, ALT1 or ALT2 furthest from the transmission channel.

- Resolution bandwidth  $RBW \leq 1/40$  of channel bandwidth
- Video bandwidth  $VBW \geq 3 \times RBW$
- Detector RMS detector

The trace mathematics and trace averaging functions are switched off.

The reference level is not influenced by *ADJUST SETTINGS*. It has to be set separately by means of *ADJUST REF LVL*.

Adjustment is performed once; if necessary, the instrument settings can be modified afterwards.

```
Remote: SENS:POW:ACH:PRES ACP|CPOW|OBW
```

With manual setting of the measurement parameters deviating from that performed with *ADJUST SETTINGS*, the following must be borne in mind for the different parameters:

### Frequency span

The frequency span must include at least all channels to be measured.

This is the channel bandwidth when channel power is measured.

If the frequency span is large compared with the analyzed frequency section (or frequency sections), only a few pixels on the trace are available for the measurement.

### Resolution bandwidth (RBW)

To ensure an acceptable sampling rate and also the necessary selection (for inhibiting spectral components outside the channel you want to measure, especially the adjacent channels), the resolution bandwidth must be selected so that it is neither too small nor too large. As a rule of thumb, the resolution bandwidth should be set to between 1% and 4% of the channel bandwidth. A larger resolution bandwidth can be set if the spectrum within and around the channel you want to measure has a flat characteristic.

### Video bandwidth (VBW)

For a correct power measurement, the video signal must not be limited in terms of bandwidth. A restricted band of the logarithmic video signal would result in averaging and thus in too small an indication of the power (-2.51 dB for very small video bandwidths). The video bandwidth should therefore be at least three times the resolution bandwidth.

The *ADJUST SETTINGS* softkey sets the video bandwidth (VBW) as a function of the channel bandwidth as follows:

$$VBW \geq 3 \times RBW.$$

### Detector

The *ADJUST SETTINGS* softkey selects the RMS detector.

The RMS detector is selected because it always indicates the power correctly irrespective of the characteristics of the signal you want to measure. Generally speaking, the sample detector would also be possible. However, this would lead to more unstable results due to

the limited number of trace pixels for calculating the power in the channel. Averaging, which is often performed to stabilize the measurement results, produces a level display that is too low and must therefore be avoided. The reduction in the displayed power depends on the number of averages and the signal characteristics in the channel you want to measure.

### **SWEEP TIME**

The *SWEEP TIME* softkey activates entry of the sweep time. A longer sweep time results in more stable measurement results with the RMS detector.

This setting is identical to the *SWEEP TIME MANUAL* setting in the *BW* menu.

Remote: SWE:TIM <value>

### **NOISE CORR ON/OFF**

The *NOISE CORR ON/OFF* softkey enables correction of the measurement results by the instrument's inherent noise, thus raising the dynamic response.

When the function is enabled, a reference measurement of the instrument's inherent noise is first made. The measured noise power is then subtracted from the power in the channel being analyzed. The inherent noise of the instrument depends on the selected center frequency, resolution bandwidth and level setting. Correction is therefore disabled whenever one of these parameters is changed, and an appropriate message appears on the screen.

To reactivate correction of the inherent noise with the changed setting, press the softkey once more. A new reference measurement is then made.

Remote: SENS:POW:NCOR ON | OFF

### **FAST ACLR**

The *FAST ACLR* softkey toggles between measurement by the IBW method (*FAST ACLR OFF*) and the time domain method (*FAST ACLR ON*).

With *FAST ACLR ON*, the power is measured in the various channels in the time domain. The analyzer adjusts its center frequency to the different channel center frequencies in sequence and measures the power there with the set measuring time (i.e. sweep time/number of measured channels). The RBW filters suitable for the selected standard and frequency offset are used automatically.

The RMS detector is used for correct power measurement. This means that software correction factors are not necessary.

Measured values are displayed in a table; the power in the useful channel is specified in dBm and the power in the adjacent channels in dBm (*ACLR ABS*) or dB (*ACLR REL*).

Selection of the sweep time (= measurement time) depends on the required reproducibility of the measurement results. The longer the selected sweep time, the better the reproducibility of the measurement results will be since the power is measured over a longer period of time.

As a rule of thumb, it can be assumed for a reproducibility of 0.5 dB (99% of the measurements are within 0.5 dB of the true measured value) that approximately 500

uncorrelated measured values are necessary (applies to white noise). The measured values are assumed to be uncorrelated when their spacing in time corresponds to the reciprocal value of the measurement bandwidth ( $= 1/BW$ ).

With 1xEV-DO the measurement bandwidth is 10 kHz, i.e. measured values at an interval of 10  $\mu$ s are assumed to be uncorrelated. Thus a measurement time (sweep time) of 50 ms per channel is required for 500 measured values. This is the default sweep time which the analyzer sets in coupled mode. Approximately 5000 measured values (i.e. the measurement time has to be extended to 500 ms) are required for a reproducibility of 0.1 dB (99% of all measurements are within 0.1 dB of the true measured values).

Remote: SENS:POW:HSP ON | OFF

### DIAGRAM FULL SIZE

The *DIAGRAM FULL SIZE* softkey switches the diagram to full screen size.

Remote: --

### ADJUST REF LVL

The ADJUST REF LVL softkey adjusts the reference level of the analyzer to the measured channel power. This ensures that the settings of the RF attenuation and the reference level are optimally adjusted to the signal level without the analyzer being overloaded or the dynamic response being limited by too low a signal-to-noise ratio.

Since the measurement bandwidth is distinctly narrower for channel power measurements than the signal bandwidth, the signal branch can be overloaded, even though the trace is still well below the reference level.

Remote: SENS:POW:ACH:PRES:RLEV

### ACLR LIMIT CHECK

The *ACLR LIMIT CHECK* softkey enables and disables the limit check for the ACLR measurement.

Remote: CALC:LIM:ACP ON  
 CALC:LIM:ACP:ACH:RES?  
 CALC:LIM:ACP:ALT1..11:RES?

### EDIT ACLR LIMIT

The default settings of limits are defined at the start of the adjacent channel power measurement as a function of the selected band class (see the BAND CLASS softkey), as in the tables on page 31. Similarly, the values in these tables are restored if the band class is changed. After the band class has been selected, a table can be opened in the ACLR measurement, however, by means of the *EDIT ACLR LIMITS* softkey and the limits for the ACLR measurement can be modified in the table.

ACP LIMITS				
CHAN	RELATIVE LIMIT CHECK		ABSOLUTE LIMIT CHECK	
	VALUE	ON	VALUE	ON
ADJ	-42 dBc	*	-70.2 dBm	*
ALT1	-54 dBc	*	-70.2 dBm	*
ALT2	-54 dBc	*	-70.2 dBm	*

The following rules apply for limit values:

A limit value can be defined for each of the adjacent channels. The limit value applies to both the upper and lower adjacent channel.

A relative limit and/or an absolute limit can be defined. The check can be activated separately for the two limit values.

Compliance with active limit values is checked irrespective of whether absolute or relative limits are specified or whether the measurement itself is performed with absolute levels or a relative level ratio. If both checks are active and if the higher of the two limits has been exceeded, the measured value concerned is marked.



Measured values which violate the limit are preceded by an asterisk and highlighted in red.

```
Remote: CALC:LIM:ACP ON
        CALC:LIM:ACP:ACH 0dB,0dB
        CALC:LIM:ACP:ACH:STAT ON |OFF
        CALC:LIM:ACP:ACH:ABS -10dBm,-10dBm
        CALC:LIM:ACP:ACH:ABS:STAT ON
        CALC:LIM:ACP:ALT1 0dB,0dB
        CALC:LIM:ACP:ALT1:STAT ON
        CALC:LIM:ACP:ALT1:ABS -10dBm,-10dBm
        CALC:LIM:ACP:ALT1:ABS:STAT ON
        CALC:LIM:ACP:ALT2..11 0dB,0dB
        CALC:LIM:ACP:ALT2..11:STAT ON
        CALC:LIM:ACP:ALT2..11:ABS -10dBm,-10dBm
        CALC:LIM:ACP:ALT2..11:ABS:STAT ON
```

## CHANNEL BANDWIDTH

The *CHANNEL BANDWIDTH* softkey activates entry of the channel bandwidth for the transmission channel.

The useful channel bandwidth is normally determined by the transmission procedure. With 1xEV-DO, measurements are performed at the default setting with a channel bandwidth of 1.2288 MHz.

In measurement by the IBW method (*FAST ACLR OFF*), the channel bandwidth is represented onscreen by two vertical lines left and right of screen center. This allows a visual check to determine whether the total power of the signal measured is within the selected channel bandwidth.

With the time domain method (*FAST ACLR ON*), the measurement is performed in zero span. The channel limits are not identified here. The analyzer provides all available channel filters for selection of the channel bandwidth entry. Any channel bandwidths deviating from this cannot be set. Should deviating channel bandwidths be necessary, you should measure by the IBW method.

```
Remote: SENS:POW:ACH:BWID 1.2288MHz
```

### ADJ CHAN BANDWIDTH

The *ADJ CHAN BANDWIDTH* softkey opens a table for definition of the channel bandwidths for adjacent channels.

ACP CHANNEL BW	
CHAN	BANDWIDTH
ADJ	30 kHz
ALT1	30 kHz
ALT2	30 kHz

When using the IBW method (*FAST ACLR OFF*), enter the bandwidths of the different adjacent channels numerically. All adjacent channels frequently have the same bandwidth, so entering the adjacent channel bandwidth ADJ also sets the other channels ALT1 and ALT2 to the bandwidth of the adjacent channel. This means that only one value has to be entered when adjacent channel bandwidths are identical. The same applies to the ALT2 channel (alternate channel 2) when entering the bandwidth of the ALT1 channel (alternate channel 1).



Bandwidths can be set independently of each other by overwriting the table from top to bottom.

With the time domain method (*FAST ACLR ON*), the adjacent channel bandwidths are selected from the list of available channel filters. Use the IBW method for deviating adjacent channel bandwidths.

```
Remote: SENS:POW:ACH:BWID:ACH 30kHz
        SENS:POW:ACH:BWID:ALT1 30kHz
        SENS:POW:ACH:BWID:ALT2..11 30kHz
```

### ADJ CHAN SPACING

The *ADJ CHAN SPACING* softkey opens a table for defining the channel spacings.

CHANNEL SPACING	
CHAN	SPACING
ADJ	885 kHz
ALT1	1.98 MHz
ALT2	4.00 MHz

Adjacent channels frequently have identical spacings, so entering the adjacent channel spacing ADJ sets channel ALT1 to twice and channel ALT2 to three times the channel spacing of the adjacent channel. This means that only one value has to be entered when channel spacings are identical. The same applies to the ALT2 channel when entering the spacing of the ALT1 channel.



Channel spacings can be set independently of each other by overwriting the table from top to bottom.

```
Remote: SENS:POW:ACH:SPAC:ACH 750kHz
        SENS:POW:ACH:SPAC:ALT1 1.98MHz
        SENS:POW:ACH:SPAC:ALT2 11 4MHz
```

**ACLR ABS/REL**

The *ACLR ABS / REL* softkey toggles between absolute and relative measurement of the channel power.

**ACLR ABS** The absolute value of the power in the transmission channel and the adjacent channels is displayed in the units of the y-axis, e.g. dBm, dB $\mu$ V.

**ACLR REL** In adjacent channel power measurement (*NO. OF ADJ CHAN* > 0), the level of the adjacent channels is displayed relative to the level of the transmission channel in dBc.

With linear scaling of the y-axis, the relative power ( $CP/CP_{ref}$ ) of the new channel to the reference channel is displayed. With dB scaling, the logarithmic ratio  $10 \cdot \lg(CP/CP_{ref})$  is displayed. This means that the relative channel power measurement can also be used for universal adjacent channel power measurements. In this instance, each channel is measured separately.

Remote: SENS:POW:ACH:MODE ABS

**CHAN PWR / HZ**

The *CHAN PWR / HZ* softkey toggles between measurement of the total power in the channel and measurement of the power in the channel referred to 1 Hz bandwidth.

The conversion factor is  $10 \cdot \lg \frac{1}{\text{Channel} \cdot \text{Bandwidth}}$ .

Remote: CALC:MARK:FUNC:POW:RES:PHZ ON|OFF

**POWER MODE**

The *POWER MODE* sub menu allows to change between the normal (*CLEAR/WRITE*) and the max hold power mode. In the *CLEAR/WRITE* the channel power and the adjacent channel powers are calculated directly from the current trace. In *MAX HOLD* mode the power values are still derived from the current trace, but they are compared with a maximum algorithm to the previous power value. The greater value is remained.

Remote: CALC:MARK:FUNC:POW:MODE WRIT|MAXH

## 6.3 Checking signal power - SPECTRUM EM MASK

*MEAS* key or *MEAS* hotkey

**SPECTRUM EM MASK**

<a href="#">LIMIT LINE AUTO</a>
<a href="#">LIMIT LINE USER</a>
<a href="#">RESTORE STD LINES</a>
<a href="#">LIST EVALUATION</a>
<a href="#">ADJUST REF LVL</a>

The *SPECTRUM EM MASK* softkey (Spectrum Emission Mask) starts determination of the 1xEV-DO signal power at defined offsets from the carrier and compares the power



values with that of the spurious emission mask called for in the 1xEV-DO specification, in the carrier-oriented range between -4 MHz and 4 MHz.

The limits depend on the band class setting (*BAND CLASS* softkey).

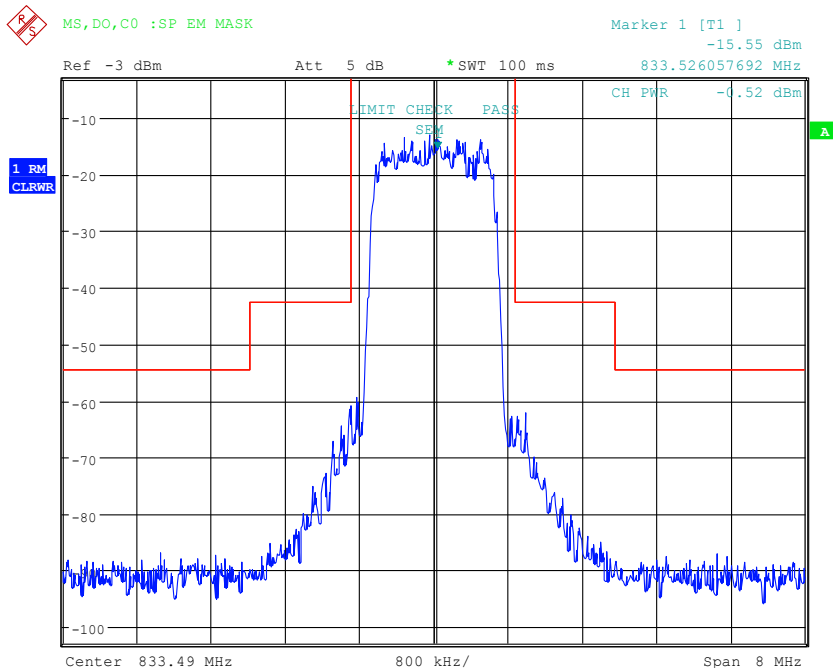

**Fig. 10 Measurement of spectrum emission mask**

The softkey activates *SPECTRUM* mode with defined settings:

The following user-specific settings are not modified on the first access following presetting:	
Level parameters	
Center Frequency + Frequency Offset	
All trigger settings	
ADJACENT CHAN POWER	ON
ACP STANDARD	cdma2000 MC1
NO OF ADJ. CHANNELS	0
FREQUENCY SPAN	8 MHz
SWEEP TIME	100 ms
DETECTOR	RMS
To restore adapted measurement parameters, the following parameters are saved on exiting and are set again on <u>re-entering</u> this measurement	
Level parameters	
RBW, VBW	
Sweep time	
SPAN	

Departing from these settings, the analyzer can be operated in many functions featured in *SPECTRUM* mode. Changes to the RBW and VBW are limited because

they are specified by the definition of the limits. If the span is extended beyond 8 MHz, the analyzer automatically switches from the carrier to the 1 MHz channel filter for the frequency range from 4 MHz and higher.

```
Remote: CONF:CDP:MEAS ESP
Query of results: CALC:LIM:FAIL?
Query of results of worst fail::
          CALC:LIM:ESP:CHEC:X?
          CALC:LIM:ESP:CHEC:Y?
```

### LIMIT LINE AUTO

The *LIMIT LINE AUTO* softkey automatically selects the limit line to be checked after the power in the useful channel has been determined. If the measurement is performed in a *CONTINUOUS SWEEP* and the channel power varies from sweep to sweep, this can result in continuous replotting of the limit line.

The softkey is activated when you enter spectrum emission mask measurement.

```
Remote: CALC:LIM:ESP:MODE AUTO
```

The definition of the limit line names is described under the *LIMIT LINE USER* softkey.

The relative limit lines are relative to the power in the channel (dBc). If both relative and absolute limits are defined for a frequency range, the resulting line is determined in the *LIMIT LINE AUTO* mode according to the "less stringent" criterion. Since these limit lines are of the 'upper limit line' type, this means that the higher limit in the level is used for comparison.



The limit is corrected by  $10 \log \text{RBW} - 10 \log 30 \text{ kHz}$  for limit values which are not specified for 30 kHz or 1 MHz bandwidth in the standard.

The band classes 0, 2, 3, 5, 9, 10, 11 and 12 have the same frequency support points. Minor modifications exist for band classes 3, 7 and 10 which means that these band classes have to be defined separately.

**Table 11 Band class 0, 2, 5, 9, 11, 12**

Offset frequency	Relative limit DOM0_R.LIM	Absolute limit DOM0_A.LIM	RBW
-4.00 MHz	-54 dBc	-70.2 dBm	30 kHz
-1.98 MHz	-54 dBc	-70.2 dBm	30 kHz
-1.98 MHz	-42 dBc	-70.2 dBm	30 kHz
-885 kHz	-42 dBc	-70.2 dBm	30 kHz
+885 kHz	-42 dBc	-70.2 dBm	30 kHz
+1.98 MHz	-42 dBc	-70.2 dBm	30 kHz
+1.98 MHz	-54 dBc	-70.2 dBm	30 kHz
+4.00 MHz	-54 dBc	-70.2 dBm	30 kHz

Table 12 Band class 3

Offset frequency	Relative limit DOM3_R.LIM	Absolute limit DOM3_A.LIM	RBW
-4.00 MHz	-54 dBc		30 kHz
-1.98 MHz	-54 dBc	+200 dBm	30 kHz
-1.98 MHz	-42 dBc	-70.2 dBm	30 kHz
-885 kHz	-42 dBc	-70.2 dBm	30 kHz
+885 kHz	-42 dBc	-70.2 dBm	30 kHz
+1.98 MHz	-42 dBc	-70.2 dBm	30 kHz
+1.98 MHz	-54 dBc	+200 dBm	30 kHz
+4.00 MHz	-54 dBc		30 kHz

Table 13 Band class 7

Offset frequency	Relative limit DOM7_R.LIM	Absolute limit DOM7_A.LIM	RBW
-4.00 MHz		-28.2 dBm	30 kHz
-2.25 MHz	+200 dBc	-28.2 dBm	30 kHz
-2.25 MHz	-54 dBc	-70.2 dBm	30 kHz
-1.98 MHz	-54 dBc	-70.2 dBm	30 kHz
-1.98 MHz	-42 dBc	-70.2 dBm	30 kHz
-885 kHz	-42 dBc	-70.2 dBm	30 kHz
+885 kHz	-42 dBc	-70.2 dBm	30 kHz
+1.98 MHz	-42 dBc	-70.2 dBm	30 kHz
+1.98 MHz	-54 dBc	-70.2 dBm	30 kHz
+2.25 MHz	-54 dBc	-70.2 dBm	30 kHz
+2.25 MHz	+200 dBc	-28.2 dBm	30 kHz
+4.00 MHz		-28.2 dBm	30 kHz

Table 14 Band class 10

Offset frequency	Relative limit DOMX_R.LIM	Absolute limit DOMX_A.LIM	RBW
-4.00 MHz		-13 dBm	30 kHz
-1.25 MHz	+200 dBc	-13 dBm	30 kHz
-1.25 MHz	-42 dBc	-70.2 dBm	30 kHz
-885 kHz	-42 dBc	-70.2 dBm	30 kHz
+885 kHz	-42 dBc	-70.2 dBm	30 kHz
+1.25 MHz	-42 dBc	-70.2 dBm	30 kHz
+1.25 MHz	+200 dBc	-13 dBm	30 kHz
+4.00 MHz		-13 dBm	30 kHz

The limits for band classes 1, 4, 6, 8, 14 and 15 are defined by separate limits. The frequency limit relative to the carrier in particular is not defined at 885 kHz but rather at

1.25 MHz

Table 15 Band class 1, 4, 8, 14 und 15

Offset frequency	Relative limit DOM1_R.LIM	Absolute limit DOM1_A.LIM	RBW
-4.00 MHz	-50 dBc	-70.2 dBm	30 kHz
-1.98 MHz	-50 dBc	-70.2 dBm	30 kHz
-1.98 MHz	-42 dBc	-70.2 dBm	30 kHz
-1.25 MHz	-42 dBc	-70.2 dBm	30 kHz
+1.25 MHz	-42 dBc	-70.2 dBm	30 kHz
+1.98 MHz	-42 dBc	-70.2 dBm	30 kHz
+1.98 MHz	-50 dBc	-70.2 dBm	30 kHz
+4.00 MHz	-50 dBc	-70.2 dBm	30 kHz

The limits for band class 6 are derived from the limits of band classes 1, 4 and 8. The additional RBW switching within the  $\pm 4$  MHz varies. The 1 MHz channel filter is used for the 1 MHz segments - highlighted in grey in the table. The frequency range is divided into three sub-segments. The user's sweep time is then distributed over the segments as follows (k = filter sweep-rate factor k):

Segment1: -4.00 ... -2.25 MHz RBW = 1 MHz k = 850 SWT1 = SWT \* 1/10

Segment2: -2.25 ... +2.25 MHz RBW = 30 kHz k = 2.5 SWT2 = SWT \* 8/10

Segment3: +2.25 ... 4.00 MHz RBW = 1 MHz k = 850 SWT3 = SWT \* 1/10

For larger spans, the sweep time is adjusted so that the three areas are swept at a constant filter sweep-rate factor k.

A further distinction in the case of band class 6 is the gradient between 2.25 MHz and 4.00 MHz.

Table 16 Band class 6

Offset frequency	Relative limit DOM6_R.LIM	Absolute limit DOM6_A.LIM	RBW
-4.00 MHz		-14.75 dBm	1 MHz
-2.25 MHz	+200 dBc	-13 dBm	1 MHz
-2.25 MHz	-50 dBc	-70.2 dBm	30 kHz
-1.98 MHz	-50 dBc	-70.2 dBm	30 kHz
-1.98 MHz	-42 dBc	-70.2 dBm	30 kHz
-1.25 MHz	-42 dBc	-70.2 dBm	30 kHz
+1.25 MHz	-42 dBc	-70.2 dBm	30 kHz
+1.98 MHz	-42 dBc	-70.2 dBm	30 kHz
+1.98 MHz	-50 dBc	-70.2 dBm	30 kHz
+2.25 MHz	-50 dBc	-70.2 dBm	30 kHz
+2.25 MHz	+200 dBc	-13 dBm	1 MHz
+4.00 MHz		-14.75 dBm	1 MHz

## LIMIT LINE USER

The *LIMIT LINE USER* softkey activates the entry of user-defined limit lines. The softkey opens the menus of the limit line editor, which may be familiar from the basic unit. The limit

lines that you create are included in the table for *LIMIT LINE MANUAL*.

The following limit line settings are recommended for mobile station tests:

Trace 1, Domain frequency, X-scaling relative, Y-scaling absolute, Spacing linear, Unit dBm.

Unlike the default limit lines which are already on the instrument when the analyzer is supplied from the factory and which conform to the standard specifications, the user-specified limit line can be specified for the entire frequency range either relatively (referred to the reference level) or absolutely.

The supplied limit lines of the AUTO mode can also be selected. The names are specified next to the type in the tables above and are defined as follows:

- Standard in 2 characters
- Link direction M for mobile station
- Band class, the lowest digit being used in the case of more than one band class
- Power classes A, B, C or \_ where A is the highest power class and is used when there is no power class dependency.
- Type distinction: A for absolute and R for relative

Example of 1xEV-DO band class 0, 2, 5, 9, 11-12:

```
DO      : 1xEV-DO
M       : mobil station
0       : lowest of band classes 0,2,5,9,11-12
_       : wildcard for power classes
R       : relative Line
```

=====

```
CDM0_R
```

The limit line names are given in the tables next to the type.

### RESTORE STD LINES

The *RESTORE STD LINES* softkey restores the limit lines defined in the standard to the state they were in when the instrument was supplied. In this way accidental overwriting of the standard lines can be undone.

```
Remote: CALC:LIM:ESP:REST
```

### LIST EVALUATION

The softkey *LIST EVALUATION* reconfigures the SEM output to a split screen. In the upper half the trace with the limit line is shown. In the lower half the peak value list is shown. For every range of the spectrum emission defined by the standard the peak value is listed. For every peak value the frequency, the absolute power, the relative power to the channel power and the delta limit to the limit line is shown. As long as the delta limit is negative, the peak value is below the limit line. A positive delta indicates a failed value. The results are then colored in red, and a star is indicated at the end of the row, for indicating the fail on a black and white printout.

If the list evaluation is active, the peak list function is not available.

```
Remote: CALC1:PEAK:AUTO ON | OFF
```

With this command the list evaluation which is by default for backwards compatibility reasons off can be turned on.

```
TRAC1:DATA? LIST
```

## Measurement of bandwidth occupied by signal - OCCUPIED BANDWIDTH

With this command the list evaluation results are queried in the following order::

<no>, <start>, <stop>, <rbw>, <freq>, <power abs>, <power rel>, <delta>, <limit check>, <unused1>, <unused2>

All results are float values.

no	range number
start	start frequency
stop	stop frequency
rbw	resolution bandwidth of range
freq	frequency of peak
power abs	absolute power in dBm of peak
power rel	relative power in dBc (related to the channel power) of peak
delta	distance to the limit line in dB (positive indicates value above the limit, fail)
limit check	limit fail (pass = 0, fail =1)
unused1	reserved (0.0)
unused2	reserved (0.0)

#### ADJUST REF LVL

The *ADJUST REF LVL* softkey adjusts the reference level of the analyzer to the measured total signal power.

The softkey becomes active when the first sweep ends with measurement of the occupied bandwidth and the total power of the signal is known.

Adaptation of the reference level ensures that the signal branch of the analyzer is not overloaded and the dynamic response is not restricted by a reference level that is too low.

Remote: SENS:POW:ACH:PRES:RLEV

## 6.4 Measurement of bandwidth occupied by signal - OCCUPIED BANDWIDTH

*MEAS* key or *MEAS* hotkey

#### OCCUPIED BANDWIDTH

The *OCCUPIED BANDWIDTH* softkey enables measurement of the bandwidth occupied by the signal.

<a href="#">% POWER BANDWIDTH</a>
<a href="#">ADJUST SETTINGS</a>
<a href="#">ADJUST REF LVL</a>

This measurement determines the bandwidth in which - in the initial state - 99 % of the signal power is found. The percentage signal power to be included in the bandwidth measurement can be modified. The bandwidth and the frequency markers for measurement are shown in the Marker info field in the top right corner of the display.

Measurement of bandwidth occupied by signal - OCCUPIED BANDWIDTH

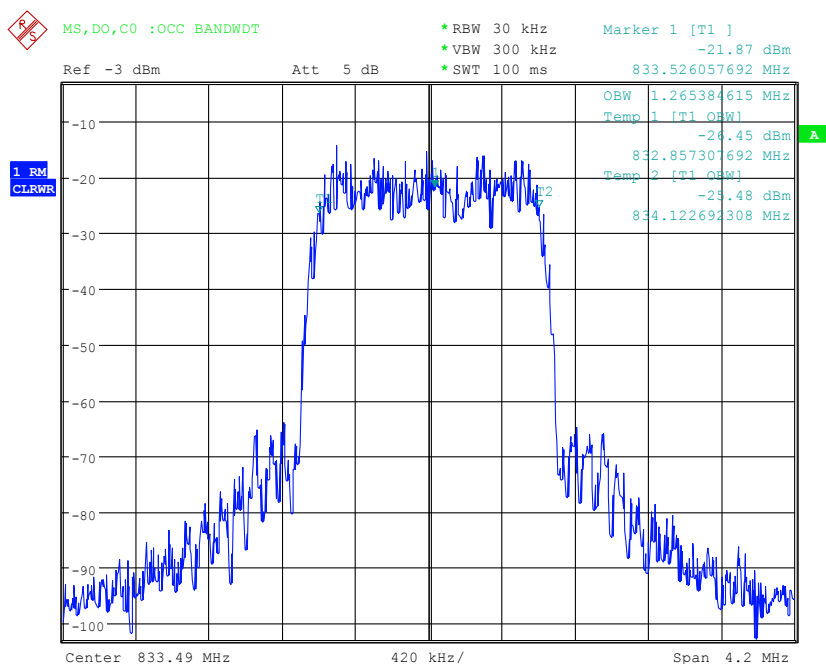

Fig. 11 Measurement of occupied bandwidth

The softkey activates *SPECTRUM* mode with defined settings:

The following user-specific settings are not modified on the first access following presetting:

- Level parameters
- Center Frequency + Frequency Offset
- All trigger settings

OCCUPIED BANDWIDTH	ON
FREQUENCY SPAN	4.2 MHz
SWEEP TIME	100 ms
RBW	30 kHz
VBW	300 kHz
DETECTOR	RMS

To restore adapted measurement parameters, the following parameters are saved on exiting and are set again on re-entering this measurement:

- Level parameters
- RBW, VBW
- Sweep time
- SPAN

Remote: CONF:CDP:MEAS OBAN

Query of results: CALC:MARK:FUNC:POW:RES? OBAN

### % POWER BANDWIDTH

The % *POWER BANDWIDTH* softkey opens a box for entering the percentage power referred to the total power in the displayed frequency range by which the occupied bandwidth is defined (percentage of total power).

The permissible range is 10 to 99.9 %.

```
Remote: SENS:POW:BWID 99PCT
```

### ADJUST SETTINGS

The *ADJUST SETTINGS* softkey adjusts the settings of the analyzer to the specified channel bandwidth for measurement of the occupied bandwidth.

- Frequency span            3 x channel width
- Resolution bandwidth     $RBW \leq 1/40$  of channel bandwidth
- Video bandwidth          $VBW \geq 3 \times RBW$
- Detector                 RMS

are optimized.

The reference level is not influenced by *ADJUST SETTINGS*. It must be set for optimum dynamic response so that the maximum signal is close to the reference level.

Adjustment is performed only once but, if necessary, the instrument settings may be changed afterwards.

```
Remote: SENS:POW:PRES OBW
```

### ADJUST REF LVL

The *ADJUST REF LVL* softkey adjusts the reference level of the analyzer to the measured total signal power.

The softkey becomes active when the first sweep ends with measurement of the occupied bandwidth and the total power of the signal is known.

Adaptation of the reference level ensures that the signal branch of the analyzer is not overloaded and the dynamic response is not restricted by a reference level that is too low.

Since the measurement bandwidth is distinctly narrower for channel power measurements than the signal bandwidth, the signal branch can be overloaded, even though the trace is still well below the reference level. When the measured channel power is identical to the reference level, the signal path is not overloaded.

```
Remote: SENS:POW:ACH:PRES:RLEV
```



## 6.5 Signal statistics

MEAS key or MEAS hotkey

### SIGNAL STATISTIC

<a href="#">APD ON/OFF</a>	
<a href="#">CCDF ON/OFF</a>	
<a href="#">PERCENT MARKER</a>	
<a href="#">NO OF SAMPLES</a>	
<a href="#">SCALING</a>	
	<a href="#">X-AXIS REF LEVEL</a>
	<a href="#">X-AXIS RANGE</a>
	<a href="#">Y-AXIS MAX VALUE</a>
	<a href="#">Y-AXIS MIN VALUE</a>
	<a href="#">ADJUST SETTINGS</a>
	<a href="#">DEFAULT SETTINGS</a>
<a href="#">CONT MEAS</a>	
<a href="#">SINGLE MEAS</a>	

The *STATISTICS* softkey launches measurement of the distribution function of signal amplitudes (complementary cumulative distribution function). The measurement can be switched, using the menu softkey, to amplitude power distribution (APD).

For this measurement, a signal section of settable length is recorded continuously in a zero span, and the distribution of the signal amplitudes is evaluated. The recording length and the display range of the CCDF can be set using the softkeys of the menu. The amplitude distribution is plotted logarithmically as a percentage of the amount by which a certain level is exceeded, starting with the mean value of the signal amplitudes.

In addition, the crest factor, i.e. the difference between the maximum value and the mean power, is displayed in dB.

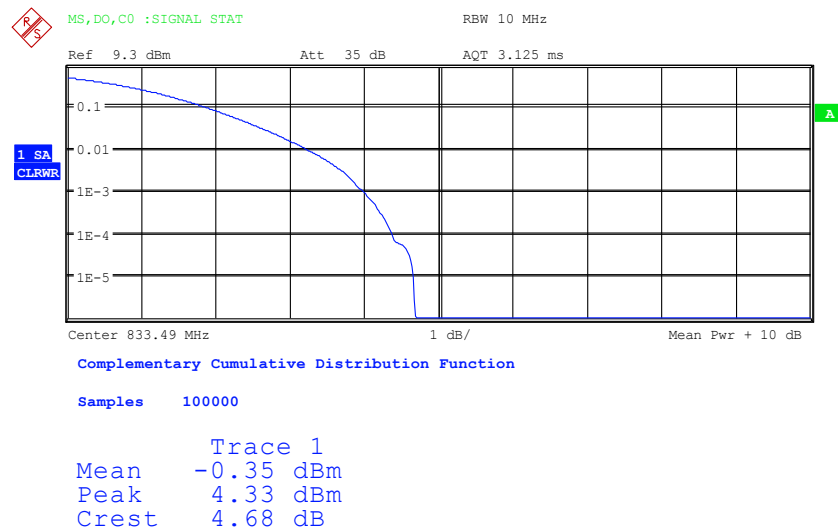

Fig. 12 CCDF of 1xEV-DO signal

The softkey enables the SPECTRUM mode with predefined settings:

The following user-specific settings are not modified so that the adaptation to the device under test is preserved: Reference Level + Ref Level Offset Center Frequency + Frequency Offset Input Attenuation + Mixer Level All trigger settings	
CCDF	ON
RBW	10 MHz
DETECTOR	SAMPLE

Departing from these settings, the analyzer can be operated in all functions featured in SPECTRUM mode, i.e. all measurement parameters can be adapted to the requirements of the specific measurement.

To restore adapted measurement parameters, the following parameters are saved on exiting and are set again on <u>re-entering</u> this measurement: Level parameters RBW NO OF SAMPLES	
--	--

```
Remote: CONF:CDP:MEAS CCDF      or
        CALC:STAT:CCDF:STAT ON | OFF
```

```
Query of results: CALC:MARK:X?
                  CALC:STAT:RES? MEAN | PEAK | CFAC | ALL
```

MEAN Mean (RMS) measured power in dBm in the period of observation

PEAK Measured peak power in dBm in the period of observation

CFAC Determined CREST factor (i.e. ratio of peak power to mean power) in dB

ALL Results of all three named measurements, separated by a comma: <mean pow>, <peak pow>, <crest factor>

### APD ON/OFF

The *APD ON/OFF* softkey enables the amplitude probability distribution function.

```
Remote: CALC:STAT:APD ON | OFF
```

### CCDF ON/OFF

The *CCDF ON/OFF* softkey enables the complementary distribution function (complementary cumulative distribution function).

```
Remote: CALC:STAT:CCDF:STAT ON | OFF
```

### PERCENT MARKER

When the CCDF function is enabled, the *PERCENT MARKER* softkey supports positioning of marker 1 by entering a sought probability. This means that the power that will be exceeded with a given degree of probability can be determined in a simple manner.

If marker 1 is disabled, it is enabled automatically.

Remote: `CALC:MARK:Y:PERC 0...100%`

### NO OF SAMPLES

The *NO OF SAMPLES* softkey sets the number of power measurement values that have to be taken into account for the distribution measurement function.



The overall measurement time is influenced by the selected number of samples as well as by the resolution bandwidth selected for the measurement, since the resolution bandwidth directly affects the sampling rate.

Remote: `CALC:STAT:NSAM <value>`

### SCALING

The *SCALING* softkey opens a menu in which the scaling parameters for the x and y-axis can be modified.

<a href="#">X-AXIS REF LEVEL</a>
<a href="#">X-AXIS RANGE</a>
<a href="#">Y-AXIS MAX VALUE</a>
<a href="#">Y-AXIS MIN VALUE</a>
<a href="#">ADJUST SETTINGS</a>
<a href="#">DEFAULT SETTINGS</a>

#### X-AXIS REF LEVEL

The *X-AXIS REF LEVEL* softkey changes the level settings of the instrument and sets the maximum measurable power.

The function is identical to that of the *REF LEVEL* softkey in the *AMPT* menu.

This value is mapped to the right diagram border for the *APD* function. For the *CCDF* function, this value is not directly represented in the diagram because the x-axis is scaled relative to the measured *MEAN POWER*.

Remote: `CALC:STAT:SCAL:X:RLEV <value>`

#### X-AXIS RANGE

The *X-AXIS RANGE* softkey changes the level range that is to be covered by the selected distribution sampling function.

The function is identical to that of the *RANGE LOG MANUAL* softkey in the *AMPT* menu.

Remote: `CALC:STAT:SCAL:X:RANG <value>`

#### Y-AXIS MAX VALUE

The *Y-AXIS MAX VALUE* softkey sets the upper limit of the displayed probability range.

The values on the y-axis are normalized, i.e. the maximum value is 1.0. Since the y-axis scaling is logarithmic, the spacing between the maximum and minimum values must be at least one decade.

Remote: `CALC:STAT:SCAL:Y:UPP <value>`

**Y-AXIS MIN VALUE**

The *Y-AXIS MIN VALUE* softkey sets the lower limit of the displayed probability range.

Since the y-axis scaling is logarithmic, the spacing between the maximum and minimum values must be at least one decade. Permissible range  $0 < \text{value} < 1$ .

Remote: `CALC:STAT:SCAL:Y:LOW <value>`

**ADJUST SETTINGS**

The *ADJUST SETTINGS* softkey optimizes the analyzer level settings according to the measured peak power in order to gain maximum sensitivity of the instrument.

In order to achieve maximum power resolution, the level range is set for the APD measurement according to the measured difference between the peak power value and the minimum power value, and for the CCDF measurement between the peak power value and the mean power value.

In addition, the probability scale of the selected number of measured values is adjusted.

Remote: `CALC:STAT:SCAL:AUTO ONCE`

**DEFAULT SETTINGS**

The *DEFAULT SETTINGS* softkey resets the scaling on the x and y-axis to the default (PRESET) settings.

X-axis reference level:	-20 dBm
X-axis range for APD:	100 dB
X-axis range for CCDF:	20 dB
Y-axis for upper limit:	1.0
Y-axis for lower limit:	1E-6

Remote: `CALC:STAT:PRES`

**CONT MEAS**

The *CONT MEAS* softkey starts the acquisition of new sequences of sample data and the calculation of the APD or CCDF trace, depending on the selected measurement. The next measurement is started automatically as soon as the indicated number of measured values has been reached ("CONTinuous MEASurement").

Remote: `INIT:CONT ON;`  
`INIT:IMM`

**SINGLE MEAS**

The *SINGLE MEAS* softkey starts the acquisition of one new sequence of sample data and the calculation of the APD or CCDF trace, depending on the selected measurement. The measurement finishes after the displayed number of measured values has been reached.

Remote: `INIT:CONT OFF;`  
`INIT:IMM`

## 6.6 Code domain measurements on 1xEV-DO signals

Application Firmware R&S FS-K85 provides a code domain analyzer. With its help, the measurements called for in the 1xEV-DO specification in respect of the power of the different codes and code channels (concentrated codes) can be performed. In addition, the modulation quality (EVM and RHO factor), frequency errors and trigger-to-frame time, and also peak-code domain errors are determined. Constellation and bit stream evaluations are also available. Furthermore the timing and phase offsets of the channels relative to the pilot can also be calculated (see the *TIME/PHASE* softkey). The observation period can be adjusted in multiples of the half slot by means of the *CAPTURE LENGTH* softkey. Each half slot has 1024 chips.

Basically, the firmware differentiates between the following result classes for the evaluations:

- Results that take the total signal into account over the whole period of observation (all half slots)
- Results that take the total signal into account over one half slot
- Results that take one channel into account over the whole period of observation (all half slots)
- Results that take one channel into account over one half slot

The evaluations of the code domain analyzer are performed on a split screen. The screen is divided into two halves for this purpose.

The upper half of the screen (Screen A) displays evaluations which vary with respect to the codes. The lower half of the screen (Screen B) displays all other evaluations.

**Table 17 Overview of evaluations**

	Code dimension		Time dimension		Mapping
Evaluation on Screen A	Total signal	One channel	All half slots	One half slot	I or Q or overview
Code-Domain-Power	✓		✓ AVG ON	✓ AVG OFF	I/Q/Overview
Code-Domain-Error-Power	✓			✓	I/Q/Overview
Channel table	☐			☐	Not used
Evaluation on Screen B	Total signal	One channel	All half slots	One half slot	I or Q
Result summary	✓		✓	✓	Not used
Power versus half slot		✓	✓		I/Q
Power versus symbol		✓		✓	I/Q
Composite EVM (modulation accuracy)	✓		✓		Not used
Composite constellation	✓			✓	Not used
Peak code domain error	✓		✓		I/Q
Symbol constellation		✓		✓	I/Q
Symbol EVM		✓		✓	I/Q
Bit stream		✓		✓	I/Q

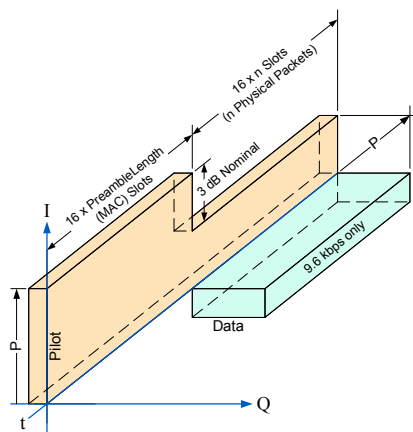

**Fig. 13 Channels in ACCESS mode**

There are two operating modes: ACCESS mode and TRAFFIC mode. The two diagrams show the possible channels together with their position on the I and Q branch, the possible orientation in time and the gain.

In ACCESS mode there is only the Reverse Pilot Channel and the Reverse Data Channel.

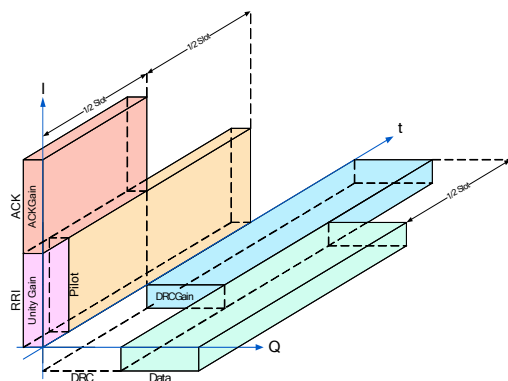

**Fig. 14 Channels in TRAFFIC mode**

The TRAFFIC mode has 5 channels:

Reverse Pilot Channel, Reverse Rate Indicator, Reverse Date Channel, Reverse Data Rate Control Channel and Reverse Acknowledgment Channel. The RRI takes up the first 256 chips of the first half slot and shares its code with the PICH. The ACK is always just one half slot in length. The DRC is a multiple of slots in length and offset by one half slot.

Depending on the symbol rate of a code channel, the code channel will have a different spreading factor and a different number of symbols per half slot. The relationship can be seen in the table below.

**Table 18 Relationship between symbol rate, spreading factor and number of symbols**

Data rate [ksps]	Spreading-factor	Symbols per half slot
76.8	16	64
153.6	8	128
307.2	4	256

With evaluations on the lower screen where symbols are entered along the x-axis, the maximum number of symbols varies according to the symbol rate of the selected code channel.

The code channel and half slot for which a result is to be displayed are selected using the *SELECT CHANNEL* and *SELECT HALF SLOT* softkeys. Let us assume that code channel 2.4 (Walsh code number 2 for spreading factor 4), half slot 3 and Q branch (using *SELECT I/Q*) have been selected. On Screen A the Code Domain Power evaluation is relative, and on Screen B the symbol EVM evaluation is active. Screen A will thus display the Code Domain Power evaluation of half slot 3. In this instance code channel 2.4 is shown selected in red. In the lower half of the screen, the EVM symbol for evaluation of code channel 2.4 in half slot 3 with 256 values can be seen.

The code domain analyzer can work in two modes. In CODE CHAN AUTOSEARCH mode, it performs an automatic search for the following 1xEV-DO and 1xEV-DV channels:

*Table 19 Channels in the 1xEV-DO system*

Channel	Abbreviation	Mapping	Channel number and spreading factor
Reverse Pilot Channel	PICH	I	0.16
Reverse Rate Indicator	RRI	I	0.16
Reverse Data Channel	DATA	Q	2.4
Reverse Acknowledgment Channel	ACK	I	4.8
Reverse Data Rate Control Channel	DRC	Q	8.16

If the RRI and the PICH are active, it is assumed that for the first 256 chips (1/4 of the half slot, 1/8 of the entire slot) only the RRI and then the PICH is active in this half slot. If only the PICH is active (RRI activity 0), the PICH is active for the entire 1024 chips of the half slot.

In the another mode, CODE CHAN PREDEFINED, the user has the option of determining the active code channels in the signal by means of selectable and editable tables. The automatic channel search is then replaced by this user entry.

### 6.6.1 Presentation of evaluations - RESULTS

RESULTS hotkey or MEAS hotkey and then CODE DOM ANALYZER softkey. The RESULTS hotkey opens the submenu for choosing the evaluation. In the main menu, the most important evaluations are offered for rapid access, and advanced evaluations are available in the side menus.

<a href="#">CODE DOM POWER</a>	
<a href="#">CODE DOM ERROR</a>	
<a href="#">COMPOSITE EVM</a>	
<a href="#">PEAK CODE DOMAIN ERR</a>	
<a href="#">POWER VS HALF SLOT</a>	
<a href="#">RESULT SUMMARY</a>	
<a href="#">CHANNEL TABLE</a>	
<a href="#">SYMBOL CONST</a>	
<a href="#">SYMBOL EVM</a>	

<a href="#">BITSTREAM</a>	
<a href="#">COMPOSITE CONST</a>	
<a href="#">POWER VS SYMBOL</a>	
<a href="#">SELECT I/Q</a>	
<a href="#">SELECT</a>	
	<a href="#">CAPTURE LENGTH</a>
	<a href="#">SET COUNT</a>
	<a href="#">SET TO ANALYZE</a>
	<a href="#">SELECT CHANNEL</a>
	<a href="#">SELECT HALF SLOT</a>
<a href="#">ADJUST REF LVL</a>	



To go to the far side menu, press the NEXT hardkey twice

You can choose from the following evaluations:

CODE DOM POWER	Code domain power evaluation in relative or absolute scaling (depending on the CODE PWR ABS/REL softkey) and with or without averaging over all half slots (depending on the CDP AVG OFF/ON softkey)
CODE DOM ERROR	Code domain error-power evaluation
COMPOSITE EVM	Square difference between the test signal and the ideal reference signal
COMPOSITE CONST	Composite constellation evaluation
RESULT SUMMARY	Results in tabular form
CHANNEL TABLE	Channel occupancy table
PEAK CODE DOMAIN ERR	Projection of the error between the test signal and the ideal reference signal to the spreading factor of the channel type and subsequent summation over the symbols of each slot of the differential signal.
POWER VS HALF SLOT	Power of the selected channel over all half slots
POWER VS SYMBOL	Power of the selected channel and the selected half slot over all symbols
BITSTREAM	Display of determined bits
SYMBOL CONST	Symbol constellation evaluation
SYMBOL EVM	Error vector magnitude evaluation

The *SELECT I/Q* softkey determines whether the I or Q branch is to be evaluated.

By entering a channel number (*SELECT CHANNEL* softkey) you can select a channel for the *POWER VS HALF SLOT*, *SYMBOL CONST*, *SYMBOL EVM*, *BITSTREAM* and *POWER VS SYMBOL* evaluations.

With the *SELECT HALF SLOT* softkey you can select a half slot for the *CODE DOM POWER*, *CODE ERROR*, *CHANNEL TABLE*, *SYMB CONST*, *SYMBOL EVM*,



*BITSTREAM*, *COMPOSITE CONST* and *POWER VS SYMBOL* evaluations.

With *ADJUST REF LVL* you can optimally adapt the reference level of the instrument to the signal level.

The following user-specific settings are not modified so that the adaptation to the device under test is preserved:

- Level parameters
- Center Frequency + Frequency Offset

The following user-specific settings are adopted as follows:

- External trigger sources are preserved, while all other trigger sources result in *FREE RUN* mode.
- Additional trigger settings are preserved.

To restore adjusted level parameters, they are saved on exiting the code domain analyzer and reset on re-entering the code domain analyzer.

The most important measurement settings, which are based on the displays, are grouped above the diagram:

```
MS,DO,C1 :CODE POWER                SR 307.2 kspS
                                         Chan  2.4 -Q
dB TOT                CF 1.85125 GHz   Half Slot  11
```

**Fig. 15 Function fields of diagrams**

The meanings are as follows:

Column 1:	Mobile radio system (mobile station 1xEV-DO) Band class (classes 0 to 12) abbreviated Name of selected evaluation: (blank line) Unit of y-axis	MS, DO  e.g. C1 for 1900 MHz Band e.g. CODE POWER  e.g. dB TOT for relative to total power
Column 2:	(blank line) (blank line) Center frequency of signal:	e.g. CF 1.85125 GHz
Column 3:	Symbol rate of selected channel: Walsh code and spreading factor of selected channel and branch (I or Q): Half slot number of selected channel	e.g. SR 307.2 kspS e.g. Chan 2.4-Q  Half Slot 11

### CODE DOM POWER

The *CODE DOM POWER* softkey selects the code domain power (CDP) evaluation with relative scaling.

In code domain power evaluation, the total signal is considered over precisely one half slot. The power values of the different codes are determined and plotted in a diagram. In this diagram, the x-axis is the code number and the y-axis is a logarithmic level axis. The number of codes on the x-axis is 16. The half slot to be evaluated can be set by means of the *SELECT HALF SLOT* softkey. The *SELECT I/Q* softkey is used to select the branch to be evaluated.

If the *CDP AVG* softkey is set to ON, evaluation is not averaged over one individual half slot but instead over all recorded half slots. The averaged evaluation is a requirement of the standard and has a special averaging algorithm for the ACK.

The power is referred in the default setting to the total power. This power reference was selected since the power control always affects all code channels including the pilot. The power reference can be switched to the power of the pilot using the *POWER REF* softkey; this allows the power of each code channel to be analyzed relative to the pilot. Power control does not change these relative results.

Apart from these relative displays, there is also the option of specifying the absolute power. It can be enabled by means of the *CODE PWR ABS/REL* softkey. Accordingly, the unit of the y-axis is dBm for absolute evaluation, dB PICH for relative evaluation with respect to the pilot, and dB TOT for relative evaluation with respect to the total power.

The power values of the active and unassigned codes are shown in different colors. Additionally, quasi-inactive codes may also occur. The following colour-coding is used:

- yellow Active channel
- cyan Unassigned code (neither on I nor Q branch)
- magenta Quasi-inactive code (the code on the analyzed branch is inactive, but the code with the same code number on the other branch belongs to an active channel)

A channel in *CODE CHAN AUTOSEARCH* mode (automatic channel search mode) is referred to as active when the minimum power entered by the user (see the *INACT CHAN THRESHOLD* softkey) is exceeded and there is an adequate signal-to-noise ratio. In *CODE CHAN PREDEFINED* mode, each code channel in the user-defined channel table is identified as active.

The code domain power evaluation supports two sorting orders: the Hadamard and BitReverse orders. In Hadamard order, the codes are sorted and displayed in ascending order: 0.16, 1.16, 2.16, ..., 15.16. The power in the code is displayed for each code. If there is a code channel in the signal that covers several codes, the individual power of the codes is displayed. If you wish to read the total power of this concentrated code channel, you should use BitReverse order.

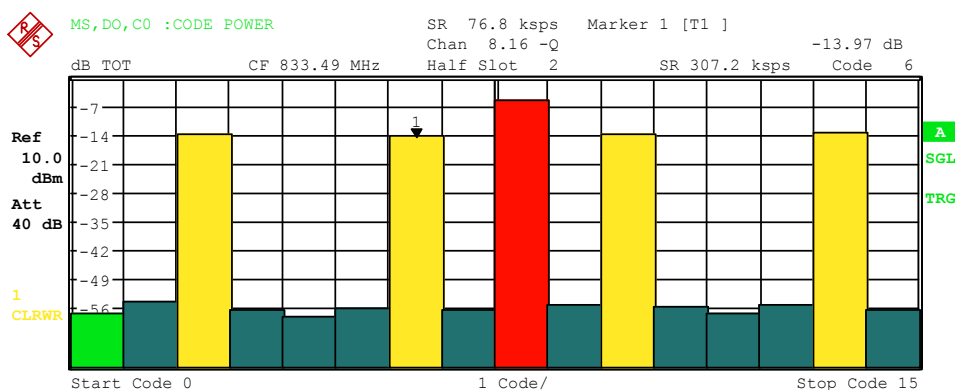

Fig. 16 CDP diagram in Hadamard order

With BitReverse order, the sorting sequence of the channels is different since the code numbers are interpreted in reverse order at bit level. This results in the following code sequence for spreading factor 16: 0.16, 8.16, 4.16, ... 15.16 (see Chapter 9). The codes of

a concentrated code channel are now adjacent to each other and the total power of the code channel is displayed.

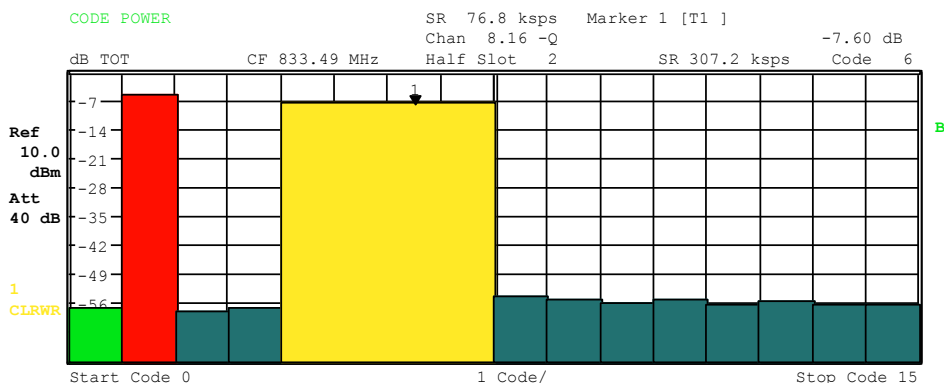

Fig. 17 DP diagram in BitReverse order for the same signal

By entering a channel number (see the *SELECT CHANNEL* softkey), you can select a channel for more detailed display. The codes of this channel are shown in red.

Selection of more detailed evaluations (e.g. *SYMBOL CONSTELLATION*) for unassigned codes is possible but pointless since the results are not valid.

To give an overview of the two code domain power measurements in addition to the separate evaluation of the I and Q branches, a *CODE DOM OVERVIEW* softkey, which can be used to switch to Overview mode, is provided in the *SETTINGS* menu. In Overview mode, the I branch is evaluated on Screen A and the Q branch on Screen B.



Fig. 18 CDP diagram in BitReverse order in Overview mode

```
Remote: CALC<1>:FEED "XPOW:CDP:RAT" (relative)
        CALC<1>:FEED "XPOW:CDP" (absolute)
```

**CODE DOM ERROR**

The *CODE DOM ERROR* softkey selects evaluation of code domain error power (CDEP).

The code domain error-power measurement reads out the difference in power between measured and ideally generated reference signals for each code in dB. Since it is an error power, active and inactive channels can be assessed jointly at a glance with this evaluation.

With the code domain error-power evaluation, the total signal is considered over precisely one half slot and the error powers are determined for the different codes and plotted in a diagram. In this diagram, the x-axis is the code number and the y-axis a logarithmic level axis with units of dB. The number of codes on the x-axis is 16. The half slot to be evaluated can be set by means of the *SELECT HALF SLOT* softkey. The *SELECT I/Q* softkey is used to select the branch to be evaluated.

The power values of the active and unassigned codes are shown in different colors. Additionally, quasi-inactive codes may also occur. The following colour-coding is used:

- Yellow Active channel
- cyan Unassigned code (neither on I nor Q branch)
- Light green Quasi-inactive code (the code on the analyzed branch is inactive, but the code with the same code number on the other branch belongs to an active channel)

A channel in *CODE CHAN AUTOSEARCH* mode (automatic channel search mode) is referred to as active when the minimum power entered by the user (see the *INACT CHAN THRESHOLD* softkey) is exceeded and there is an adequate signal-to-noise ratio. In *CODE CHAN PREDEFINED* mode, each code channel in the user-defined channel table is identified as active.

The code domain error-power evaluation supports two sorting orders: the Hadamard and BitReverse orders. In Hadamard order, the codes are sorted and displayed in ascending order: 0.16, 1.16, 2.16, ..., 15.16. The power in the code is displayed for each code.

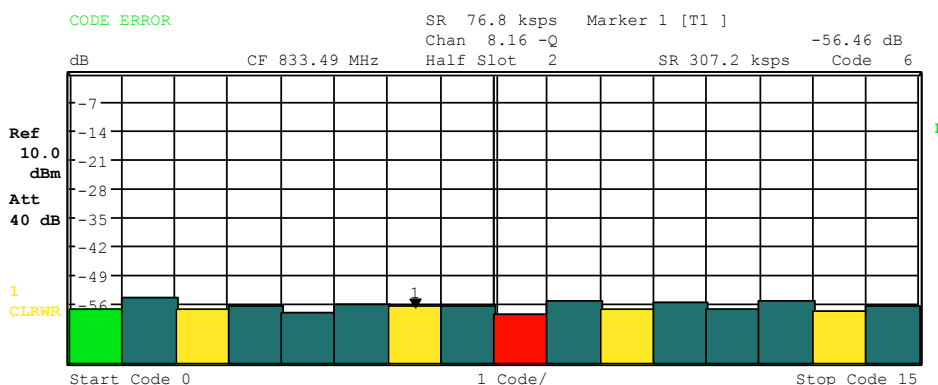

**Fig. 19 CDEP diagram in Hadamard order**

With BitReverse order, the sorting sequence of the channels is different since the code numbers are interpreted in reverse order at bit level. This results in the following code sequence for base spreading factor 16: 0.16, 8.16, 4.16, ... 15.16 (see Chapter 9). With the code domain error-power evaluation, unlike the code domain power evaluation, no

power values of the concentrated code channel are displayed since the power values in the code domain error-power evaluation are error power values.

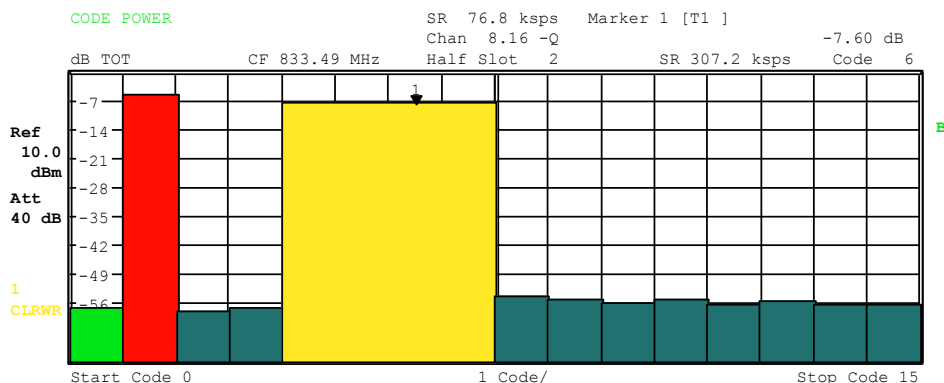

**Fig. 20 CDEP diagram in BitReverse order for the same signal**

By entering a channel number (see the *SELECT CHANNEL* softkey), you can select a channel for more detailed display. The codes of this channel are shown in red.

Selection of more detailed evaluations (e.g. *SYMBOL CONSTELLATION*) for unassigned codes is possible but pointless since the results are not valid.

To give an overview of the two code domain power measurements in addition to the separate evaluation of the I and Q branches, a *CODE DOM OVERVIEW* softkey, which can be used to switch to Overview mode, is provided in the *SETTINGS* menu. In Overview mode, the I branch is evaluated on Screen A and the Q branch on Screen B.

Remote: CALC<1>:FEED "XPOW:CDEP"

### COMPOSITE EVM

The *COMPOSITE EVM* softkey selects evaluation of error vector magnitude (EVM) over the total signal (modulation accuracy).

In the composite EVM measurement, the square root is determined from the error square between the real and imaginary components of the test signal and an ideally generated reference signal (EVM referred to the total signal).

The measurement result consists of one composite EVM measurement value per half slot. You can set the number of half slots by means of the *CAPTURE LENGTH* softkey. Subsequently, the *COMPOSITE EVM* evaluation considers the total signal over the entire period of observation.

Only the channels detected as active are used to generate the ideal reference signal. In the case of a channel which is not detected as being active on account of, for example, low power, the difference between the test/reference signal and the composite EVM is therefore very large (see the figure).

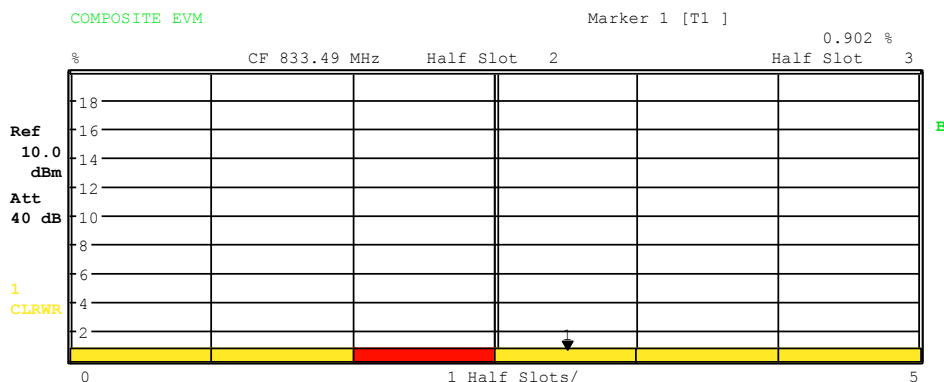

Fig. 21 Display of Composite EVM when all channels contained in the signal were detected as active

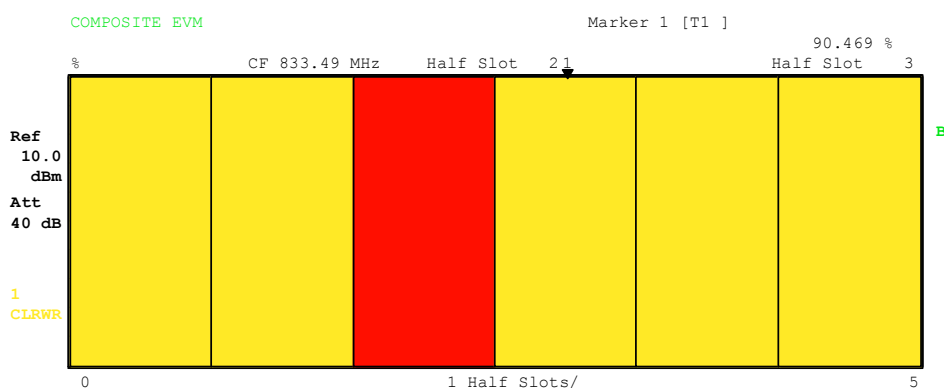

Fig. 22 Display of Composite EVM when one code channel was not detected as active

As with the selection of a code channel in the CDP or CDEP diagram, there is the option of selecting a half slot in the Composite EVM diagram. Selection is performed by entering the half-slot number (see the *SELECT HALF SLOT* softkey). The selected half slot appears as a red bar.

Remote: CALC2:FEED "XTIM:CDP:MACCuracy"

**PEAK CODE DOMAIN ERR**

The *PEAK CODE DOMAIN ERR* softkey selects the evaluation of the peak code domain error.

With the peak code domain error measurement, there is a projection of the error between the test signal and the ideally generated reference signal to the base spreading factor. The unit on the y-axis is dB. The *SELECT I/Q* softkey is used to select the branch to be evaluated.

The measurement result consists of one numerical value per half slot for the peak code domain error. You can set the number of half slots by means of the *CAPTURE LENGTH* softkey. Subsequently, peak code domain error evaluation considers the total signal over the entire period of observation.

Only the channels detected as active are used to generate the ideal reference signal for peak code domain error. If an assigned code is not detected as active because of low power, the difference between the test signal and the reference signal is very large. The R&S FS-K85 therefore shows a peak code domain error that is too high

(see figure).

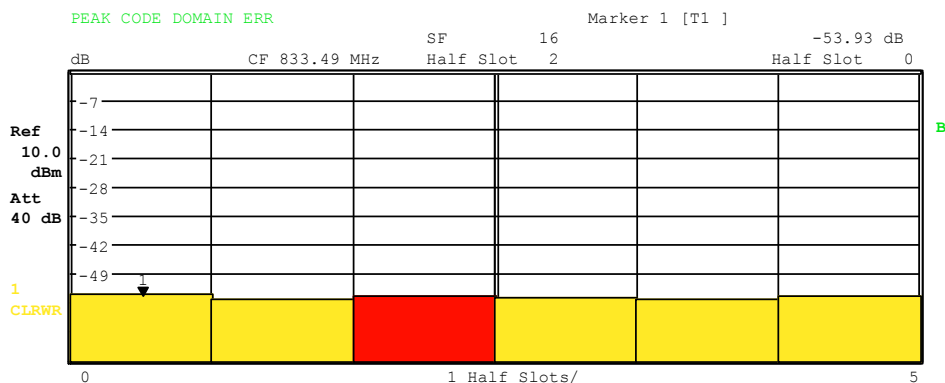

Fig. 23 Peak code domain error when all channels contained in the signal were detected as active

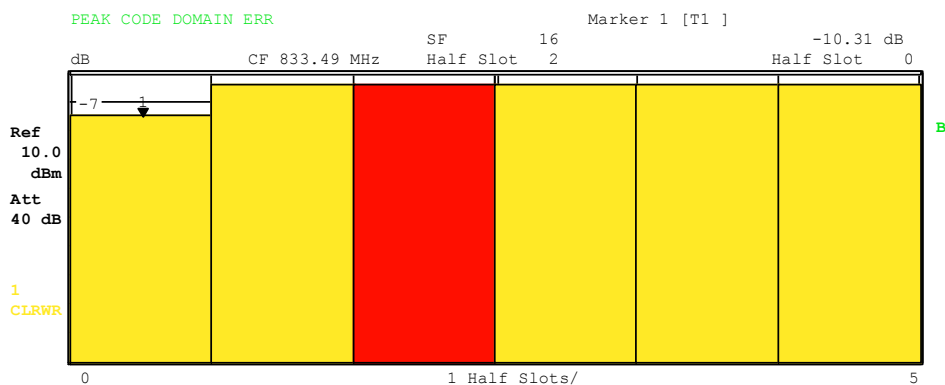

Fig. 24 Peak code domain error when all channels contained in the signal were detected as active

As with the selection of a code channel in the CDP or CDEP diagram, there is the option of selecting a half slot in the Peak Code Domain Error diagram. Selection is performed by entering the half-slot number (see the *SELECT HALF SLOT* softkey). The selected half slot appears as a red bar.

Remote: CALC2:FEED "XTIM:CDP:ERR:PCDomain"

**POWER VS HALF SLOT**

The *POWER VS HALF SLOT* softkey activates the power versus half slot evaluation.

The absolute power for the selected channel is displayed as an average for each half slot. The unit on the y-axis is dBm.

The measurement result consists of one numerical value per half slot for the power value. You can set the number of half slots by means of the *CAPTURE LENGTH* softkey. Subsequently, the *POWER VS HALF SLOT* evaluation considers one code channel over the entire period of observation.

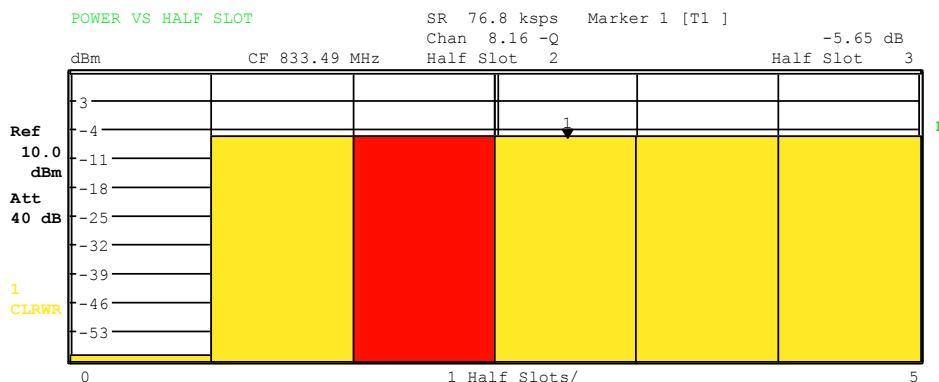

Fig. 25 Power versus half slot for an occupied channel with power control

As with the selection of a code channel in the CDP or CDEP diagram, there is the option of selecting a half slot in the Power versus Half Slot diagram. Selection is performed by entering the half-slot number (see the *SELECT HALF SLOT* softkey). The selected half slot appears as a red bar.

Remote: CALC2:FEED "XTIM:CDP:PVSLOT"

**RESULT SUMMARY**

The *RESULT SUMMARY* softkey selects the numerical evaluation of all measurement results. Evaluation is subdivided as follows:

RESULT SUMMARY TABLE

SR 76.8 ksps  
 Chan 8.16 -Q  
 CF 833.49 MHz    Half Slot 2

Results for Half Slot: 2		Global results	
Total PWR	-0.05 dBm	Carr Freq Error	209.36 mHz
Pilot PWR	-2.65 dBm	Carr Freq Error	0.00 ppm
RRI PWR	-2.65 dBm	DELTA RRI/PICH	0.00 dB
RHO	0.99992	RHO overall	0.99992
Composite EVM	0.88 %	Trg to Frame	201.332165 μs
Pk CDE (SF 16/Q)	-54.40 dB	Chip Rate Err	0.06 ppm
IQ Imbal/Offset	0.29/0.16 %	Active Channels	4
Channel results		Mapping	
Symbol Rate	76.8 ksps	Timing Offset	-0.15 ns
Channel.SF	8.16	Phase Offset	0.37 mrad
Channel Power Rel	-5.60 dB	Channel Power Abs	-5.65 dBm
Symbol EVM	0.23 % rms	Symbol EVM	0.54 % Pk

Fig. 26 Result Summary

The top left-hand part shows measurement results which affect the total signal (i.e. all channels) for the half slot selected using the *SELECT HALF SLOT* softkey:

- Total Power: Specifies the total power of the signal..
- Pilot Power: Specifies the pilot power.
- RRI Power: Specifies the RRI power; dashes are displayed if there is no RRI channel.
- RHO: Specifies the RHO quality parameter. According to the 1xEV-DO specification, RHO is the normalized, correlated power between the measured and the ideally generated reference signal. The 1xEV-DO specification requires that only the pilot channel be input during measurement of RHO.



- Composite EVM: The composite EVM value is the difference between the test signal and the ideal reference signal (see the *COMPOSITE EVM* softkey).
- Pk CDE: The *PEAK CODE DOMAIN ERR* measurement specifies a projection of the difference between the test signal and the ideal reference signal to spreading factor 16 (see softkeys *PEAK CODE DOMAIN ERR*). The spreading factor, for which the projection is made, is specified next to the measured value.
- IQ Imbalance: IQ imbalance of the signal in %
- IQ Offset: DC offset of the signal in %

The top right-hand part shows measurement results which affect the total signal (i.e. all channels) for the entire period of observation (i.e. all half slots):

- Carrier Freq Error: Specifies the frequency error referred to the set center frequency of the analyzer. The absolute frequency error is the sum of the frequency error of the analyzer and that of the device under test.
- Excessive differences between transmitter and receiver frequency impair synchronization of the CDP measurement. If at all possible, the transmitter and the receiver should therefore be synchronized to a common reference frequency (see the chapter "Getting Started"). The frequency error is available both in Hz and in ppm referred to the carrier frequency.
- DELTA RRI/PICH: This value specifies a logarithmic correlation between RRI and pilot power. The specification requires that 16 half slots be measured; this can be adjusted using the *CAPTURE LENGTH* softkey. The formula of the standard has been extended to any given number of half slots.
- RHO overall: RHO determined over all half slots.
- Trigger to Frame: This measurement result reproduces the timing offset from the beginning of the acquired signal section until the start of the first even-numbered half slot. In the case of triggered data acquisition, this corresponds to the timing offset frame-trigger (+ trigger-offset) - start of the first even-numbered half slot. If the analyzer was not able to synchronize to the 1xEV-DO signal, the value of Trg to Frame is not meaningful. If the *FREE RUN* trigger is selected, dashes (-.-) are shown.
- Chip Rate Error: Specifies the chip rate error (1.2288 Mcps) in ppm. A high chip rate error causes symbol errors and this may prevent the CDP measurement from performing synchronization. This measurement result is valid even if the analyzer was not able to synchronize to the 1xEV-DO signal.
- Active Channels: Specifies the number of active channels found in the signal. The PICH and RRI each count as an individual channel. (Display for each half slot).

The bottom part of the *RESULT SUMMARY* shows the results of measurements on the selected channel and the selected half slot.

- Symbol Rate: Symbol rate with which the channel is transmitted.

Mapping:	Indicates whether the I or Q branch is being evaluated.
Channel.SF:	Number of the channel and its associated spreading factor.
Timing Offset:	Timing offset between the selected channel and the pilot channel. This measurement can be enabled by means of the <i>TIME/PHASE</i> softkey.
Phase Offset:	Phase offset between the selected channel and the pilot channel. This measurement can be enabled by means of the <i>TIME/PHASE</i> softkey.
Chan Pow rel. / abs.:	Relative channel power (referred to the pilot or total power, depending on the <i>POWER REF TOT/PICH</i> softkey) and the absolute channel power.
Symbol EVM Pk / rms:	Peak or mean value of the results of the error vector magnitude measurement (see the <i>SYMBOL EVM</i> softkey). The measurement provides information about the EVM of the selected channel for the selected half slot at symbol level.

```
Remote: CALC2:FEED "XTIM:CDP:ERR:SUMM"
        CALC<1|2>:MARK<1>:FUNC:CDP:RES?
        PTOTal | FERRor | RHO | PPICH | PRRI | FERPpm |
        DRPich | RHOVerall | CERRor| TFRame |
        IQOffse | IQIMbalance | MACCuracy | PCDerror |
        SLOT | ACTive | SRATe | TOFFset | CHANnel |
        POFFset | SFACTor | CDPabsolute |
        CDPRelative | EVMRms | EVMPeak
```

If the *MAX/MIN HOLD* or *AVERAGE* trace statistics are enabled using the *TRACE* hardkey, the values are interlinked accordingly from one evaluation to the next.

The Active Channels, Symbol Rate, Channel.SF and Mapping values are not statistically interlinked.

In the case of the values which have an expectation value of 0 (Carr Freq Error, Trg to Frame, IQ Imbal/Offset, Timing and Phase Offset), the maximum value is formed in such a way that the maximum is sought among the absolute values and then output with sign. In this way it is possible to determine the largest deviation including the direction of the deviation. The minimum value is formed in the same way.

## CHANNEL TABLE

The *CHANNEL TABLE* softkey selects channel occupancy table evaluation.

The channel occupancy table can contain a maximum of 33 entries, corresponding to the highest base spreading factor 16 with both I and Q branch plus the RRI channel. The Channel Occupancy Table evaluation considers the total signal over precisely one power control group. The half slot to be evaluated can be set by means of the *SELECT HALF SLOT* softkey.

The channels are listed in ascending code number order (within a code number: first I and then Q branch). Unassigned codes are thus always at the end of the table.

Code domain measurements on 1xEV-DO signals

MS,DO,C0 :CHANNEL TAB

CF 833.49 MHz Chan 8.16 -Q Max T -0.40 ns @ RRI 0.16  
Half Slot 2 Max Ph -1.30 mrad @ RRI 0.16

	Type	Chan.SF	Symb Rate ksp/s	Map	Status	Pwr Abs dBm	Pwr Rel dB	T Offs ns	Ph Offs mrad	
Ref	PILOT	0.16	76.8	I	active	-2.65	-2.59	0.00	0.00	A
10.0 dBm	RRI	0.16	76.8	I	active	-2.65	-2.60	-0.40	-1.30	SGL
	DATA	2.4	307.2	Q	active	-7.65	-7.60	-0.14	-0.75	
Att	DRC	8.16	76.8	Q	active	-5.65	-5.60	-0.15	0.37	TRG
40 dB	----	0.16	76.8	Q	inact	-57.36	-57.31	----	----	
	----	1.16	76.8	I	inact	-53.88	-53.83	----	----	
	----	1.16	76.8	Q	inact	-54.45	-54.40	----	----	
	----	2.16	76.8	I	inact	-55.72	-55.67	----	----	
1	----	3.16	76.8	I	inact	-55.13	-55.08	----	----	
CLRWR	----	3.16	76.8	Q	inact	-56.17	-56.12	----	----	
	----	4.16	76.8	I	inact	-57.36	-57.31	----	----	
	----	4.16	76.8	Q	inact	-57.78	-57.72	----	----	

Fig. 27 Channel table

The following parameters are determined by CDP measurement for the channels:

- Type: Type of channel
- Chan.SF: Number of the channel spreading code (0 to [spreading factor - 1]) including the spreading factor of the channel in Chan.SF notation.
- Symb Rate: Symbol rate with which the channel is transmitted (76.8 ksp/s to 307.2 ksp/s)
- Map.: Mapping of the channel (I or Q branch)
- Status: Status display. Unassigned codes are identified as inactive channels.
- Pwr Abs / Pwr Rel: Specifies the absolute and relative (referred to the PICH or the total power of signal) power of the channel.
- T Offs: Timing offset. The timing offset between this channel and the pilot channel can be enabled by means of the *TIME/MEAS* softkey.
- Ph Offs: Phase offset. The phase offset between this channel and the pilot channel can be enabled by means of the *TIME/MEAS* softkey.

A data channel in *CODE CHAN AUTOSEARCH* mode is identified as active if it exhibits minimum power (see the *INACT CHAN THRESHOLD* softkey) and adequate signal-to-noise ratio. In *CODE CHAN PREDEFINED* mode, all code channels contained in the channel table are identified as active.

If the *TIME/PHASE* softkey is set to ON, the maximum value of the *TIMING* and *PHASE OFFSET* is displayed together with the associated channel on the right-hand side above the channel table. Since the *TIMING* and *PHASE* values of each active channel can be either negative or positive, the absolute values are compared and the maximum is then displayed with the original sign.

Remote: CALC<1>:FEED "XTIM:CDP:ERR:CTable"

**SYMBOL CONST**

The *SYMBOL CONST* softkey selects the evaluation of the constellation diagram at symbol level.

Evaluation of the symbols is performed for the selected channel (*SELECT CHANNEL* softkey) and the selected half slot (*SELECT HALF SLOT* softkey). This means that this evaluation considers results of a channel for a half slot.

The *SELECT I/Q* softkey is used to select the branch to be evaluated. Evaluation of the constellation diagram is possible for unassigned codes, but the results are meaningless since unassigned code channels do not contain data.

For orientation, the unit circle is added to the figure.

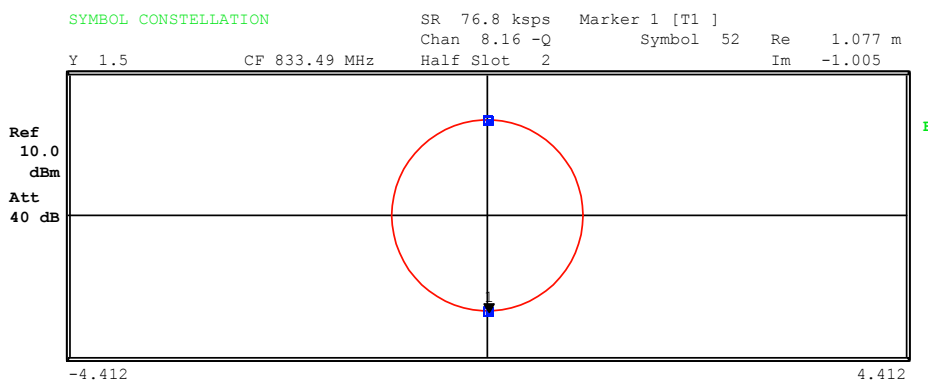

Fig. 28 Symbol constellation diagram

Remote: CALC2:FEED "XTIM:CDP:SYMB:CONS"

**SYMBOL EVM**

The *SYMBOL EVM* softkey selects symbol error vector magnitude evaluation. Evaluation of the EVM is performed for the selected channel (*SELECT CHANNEL* softkey) and the selected half slot (*SELECT HALF SLOT* softkey). This means that this evaluation considers results of a channel for a half slot. Evaluation of the symbol error vector magnitude for unassigned codes is possible, but the results are not valid.

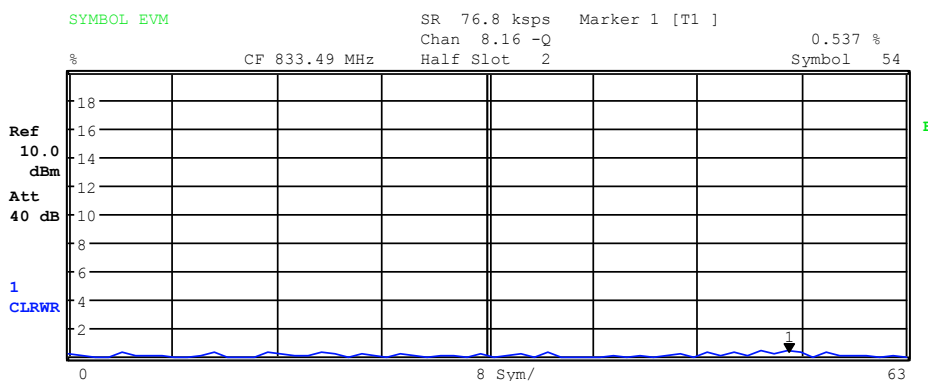

Fig. 29 Error vector magnitude for a half slot of a channel

Remote: CALC2:FEED "XTIM:CDP:SYMB:EVM"

**BITSTREAM**

The *BITSTREAM* softkey selects the "Bit Stream" evaluation.

Evaluation of the determined bits is performed for the selected channel (*SELECT CHANNEL* softkey) and the selected half slot (*SELECT HALF SLOT* softkey). This means that this evaluation considers results of a channel for a half slot. The *SELECT I/Q* softkey is used to select the branch to be evaluated.

Depending on the symbol rate of the channel, a minimum of 64 and a maximum of 256 symbols can be contained in a half slot. With BPSK-modulated channels, a symbol always consists of one bit.

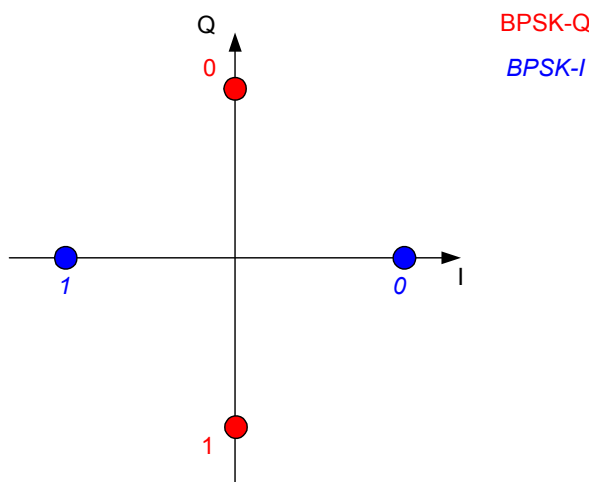
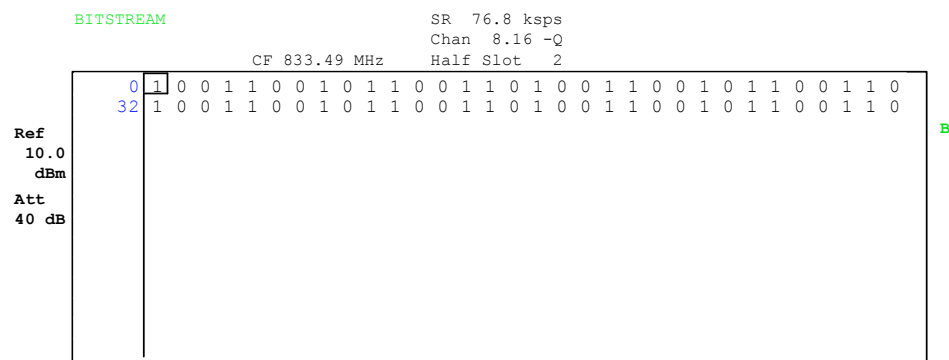

**Fig. 30 Constellation diagram for BPSK-I and BPSK-Q including bit values**

Depending on the channel type, there are BPSK-I or BPSK-Q-modulated channels in the 1xEV-DO system.

An evaluation of the bit stream for unassigned codes is indeed possible, but since the results are not meaningful on account of the missing data, all bits are identified as invalid ("-") in this case.

The marker can be used to scroll in the bit stream.

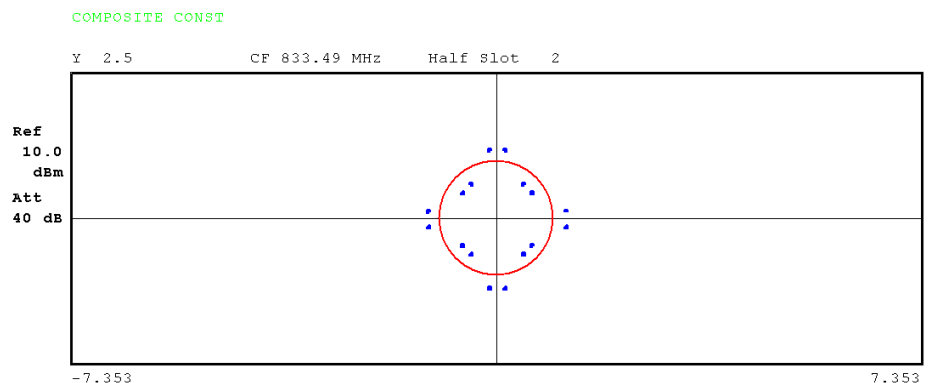

**Fig. 31 Demodulated bits for a half slot of the channel**

Remote: CALC2:FEED "XTIM:CDP:BSTream"

**COMPOSITE CONST**

The *COMPOSITE CONST* softkey selects the evaluation of the constellation diagram at chip level.  
 With *COMPOSITE CONST*, the total signal is taken into account over the selected half slot (*SELECT HALF SLOT* softkey).  
 A constellation point is plotted in the diagram for each of the 1024 chips.  
 For orientation, the unit circle is added to the figure.

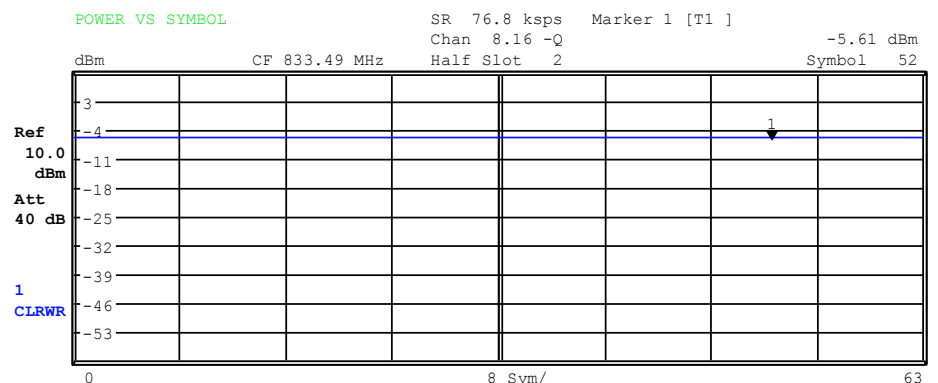

**Fig. 32 Composite Constellation Diagram**

Remote: CALC2:FEED "XTIM:CDP:COMP:CONS"

**POWER VS SYMBOL**

The *POWER VS SYMBOL* softkey selects the power versus symbol evaluation. The evaluation outputs the absolute power in dBm at each symbol time for the selected channel (*SELECT CHANNEL* softkey) and the selected half slot (*SELECT HALF SLOT* softkey). This means that this evaluation considers results of a channel for a half slot. The *SELECT I/Q* softkey is used to select the branch to be evaluated.



**Fig. 33 Power versus symbol for a half slot of a channel**

Remote: CALC2:FEED "XTIM:CDP:PVSY"

**SELECT I/Q**

The branch to be evaluated (I or Q) is selected using the *SELECT I/Q* softkey. The I branch is selected following a preset.

Remote: SENS:CDP:MAPP I | Q

**SELECT**

The *SELECT* softkey opens a submenu to define the capture configuration and the selection of half slots and channel for the evaluation.

<a href="#">CAPTURE LENGTH</a>
<a href="#">SET COUNT</a>
<a href="#">SET TO ANALYZE</a>
<a href="#">SELECT CHANNEL</a>
<a href="#">SELECT HALF SLOT</a>

**CAPTURE LENGTH**

The *CAPTURE LENGTH* softkey allows entry of the number of half slots to be acquired. The entry is always made as a multiple of the half slot. The range is from 2 to 70 for the R&S FSU, R&S FSQ analyzers and from 2 to 24 for the R&S FSP analyzer. For all evaluations that exhibit one value per half slot on the x-axis, the maximum value on the x-axis is the set *CAPTURE LENGTH* -1.

Remote: SENS:CDP:IQL 2..70 (2..24)

**SET COUNT SET TO ANALYZE**

This function offers the possibility for the R&S FSQ to capture up to 3684 half slots (more than 3 seconds) with a SINGLE SWEEP and then post process all the data with *SET TO ANALYZE*.

If the *SET COUNT* is set to 1 (default value), the device behaves as before and with the *CAPTURE LENGTH* the number of half slots can be set.

For R&S FSQ the *SET COUNT* can be adjusted in the range of 1..57. Is the *SET COUNT* greater than 1 the *CAPTURE LENGTH* will be implicitly set to 64 half slots and become unavailable. The *SET COUNT* defines then how many SETS of 64 half slots shall be captured consecutively into the IQ RAM of the R&S FSQ. With the *SET TO ANALYZE* softkey the set for which the results are calculated can be defined. The range is from 0... (SET COUNT-1).

Remote: SENS:CDP:SET:COUN 1..57 (FSQ)  
SENS:CDP:SET:VAL <numeric\_value>

**SELECT CHANNEL**

A channel is selected using the *SELECT CHANNEL* softkey. All evaluations that consider results for a channel specify the results for the newly selected channel: POWER VS HALF SLOT, POWER VS SYMBOL, RESULT SUMMARY, BITSTREAM, SYMBOL CONSTELLATION and SYMBOL EVM.

In the evaluations CODE DOM POWER, CODE DOM ERROR POWER and CHANNEL TABLE (all on Screen A), the selected channel is marked red.

Channels are entered in decimal format. The entered value is always converted to spreading factor 16. Only <channel> is displayed in the input field.

Normally the code and spreading factor 16 are displayed in the function field above the diagrams.

If, however, the current channel table contains a concentrated channel to which the selected channel belongs, this concentrated channel together with the associated code number and spreading factor is displayed in the function field and highlighted in red in the respective evaluations.

The rotating wheel action depends on the evaluation on Screen A and is geared to the graphic display. In the case of CODE DOMAIN POWER and CODE DOMAIN ERROR POWER, it depends on whether the Hadamard or BitReverse order is active. (See the *ORDER* softkey.) It is always the adjacent channel that is selected with the rotating wheel. In the channel table, the rotating wheel is used to scroll through the list. Entries made using the IEC/IEEE bus are generally referred to spreading factor 16.

Remote: SENS:CDP:CODE 0...15

### SELECT HALF SLOT

The *SELECT HALF SLOT* softkey is used to select a half slot. Half slots are entered in decimal format. Here the range is from 0 to (IQ capture length - 1) (see the *CAPTURE LENGTH* softkey). All evaluations that consider results for a half slot specify the results for the newly selected half slot. (CODE DOMAIN POWER, CODE DOMAIN ERROR POWER, CHANNEL TABLE, POWER vs. SYMBOL, COMPOSITE CONSTELLATION, RESULT SUMMARY, BITSTREAM, SYMBOL CONSTELLATION and SYMBOL EVM).

In the evaluations POWER vs. HALF SLOT, COMPOSITE EVM and PEAK CODE DOMAIN ERROR, the selected half slot is highlighted in red.

Remote: SENS:CDP:SLOT 0 ... (IQ\_CAPTURE\_LENGTH-1)

### ADJUST REF LVL

The *ADJUST REF LVL* softkey adjusts the reference level of the analyzer to the measured channel power. This ensures that the settings of the RF attenuation and the reference level are optimally adjusted to the signal level without the analyzer being overloaded or the dynamic response being limited by too low a signal-to-noise ratio.

Remote: SENS:POW:ACH:PRES:RLEV

## 6.6.2 Configuration of measurements - Hotkey *CHAN CONF*

<a href="#">CODE CHAN AUTOSEARCH</a>	
<a href="#">CODE CHAN PREDEFINED</a>	
<a href="#">EDIT CHAN CONF TABLE</a>	
	<a href="#">HEADER/VALUES</a>
	<a href="#">ADD SPECIAL</a>
	<a href="#">DELETE LINE</a>
	<a href="#">SAVE TABLE</a>
	<a href="#">SORT TABLE</a>
<a href="#">DEL CHAN CONF TABLE</a>	
<a href="#">COPY CHAN CONF TABLE</a>	
<a href="#">RESTORE STD TABLES</a>	
<a href="#">NEW CHAN CONF TABLE</a>	<a href="#">HEADER/VALUES</a>
	<a href="#">ADD SPECIAL</a>
	<a href="#">DELETE LINE</a>
	<a href="#">SAVE TABLE</a>
	<a href="#">SORT TABLE</a>



The *CHAN CONF* hotkey opens a submenu with configuration options for the channel search. In this submenu, predefined channel tables can be selected and are then taken as a basis for measurements by the code domain analyzer.

When the hotkey is clicked, a table containing the channel tables stored on the hard disk of the measuring instrument is opened. The table is merely an overview; to select one of the tables for a measurement, you must first press the *CODE CHAN PREDEFINED* softkey. The *RECENT* entry is the channel table of the last code domain power analysis that was performed.

```
Remote: CONF:CDP:CTAB:CAT?
```

### CODE CHAN AUTOSEARCH

The *CODE CHAN AUTOSEARCH* softkey supports measurements of the code domain power analyzer in automatic search mode. This mode searches the entire code domain (all permissible symbol rates and channel numbers) for active channels. A channel is active when the minimum power you enter, referred to the total power, is exceeded (see the *INACT CHAN THRESHOLD* softkey) and there is an adequate signal-to-noise ratio.

*CODE CHAN AUTOSEARCH* is the default search mode with which CDP analysis starts. It is used primarily to give you an overview of the channels contained in the signal. If the signal contains channels that are not detected as active in automatic search mode, CDP analysis can be performed with predefined channel configurations by changing to *CODE CHAN PREDEFINED* mode.

```
Remote: CONF:CDP:CTAB:STAT OFF
```

### CODE CHAN PREDEFINED

The *CODE CHAN PREDEFINED* softkey switches the CDP analysis to the measuring mode using predefined channel tables. In this mode there is no search for active channels in the code domain, instead the channels of a channel table defined prior to a measurement are assumed to be active.

When the softkey is clicked, a table containing all the channel tables stored on the measuring instrument is opened. The CDP analysis is switched to "Predefined Channel Table" mode. In this instance, a *DEFAULT* table containing only the *PICH* is taken as a basis. This table is available at the *DEFAULT* entry.

Switching to one of the predefined channel tables is done by selecting the corresponding table entry and operating one of the unit keys or by pressing Enter; the selected channel table is taken as a basis for the evaluation as from the next measurement. A checkmark indicates the selected channel table.

When the R&S FS-K85 leaves the factory, the channel tables from Chapter 4 on page 24 are stored on the measuring instrument.

```
Remote: CONF:CDP:CTAB1:STAT ON
CONF:CDP:CTAB:SEL "5CHANS"
```

### EDIT CHAN CONF TABLE

The *EDIT CHAN CONF TABLE* softkey opens the selected channel table, in which the channel configuration can be edited. In addition, a submenu opens with the softkeys

required for editing the channel table.

<a href="#">HEADER/VALUES</a>
<a href="#">ADD SPECIAL</a>
<a href="#">DELETE LINE</a>
<a href="#">SAVE TABLE</a>
<a href="#">SORT TABLE</a>

EDIT CHANNEL TABLE						
NAME:		RL_DATA				
COMMENT:		DO Reverse Link only Data Channel				
TYPE	CHAN.SF	SYMBOL RATE [ksps]	MAP- PING	ACTIVITY [0/1:Off/On in Halfslot]		STATUS
PICH	0.16	76.8	I	1111	1111 1111 1111	ACTIVE
RRI	0.16	76.8	I	1010	1010 1010 1010	ACTIVE
DATA	2.4	307.2	Q	1111	1111 0000 0000	INACTIVE

**Fig. 34** Table for editing a channel configuration

As a general rule, each of the channel tables stored on the measuring instrument can be modified at will. The edited table is not stored automatically on the hard disk of the measuring instrument but only by selecting the *SAVE TABLE* softkey. This prevents a table from being accidentally overwritten (e.g. one of the channel models).

If a table is edited that is currently the basis for code domain power analysis, the edited table is used for the next measurement immediately after it is saved. The effects of the changes in the table are therefore immediately visible. Here again, the edited table is not saved on the hard disk of the measuring instrument until the *SAVE TABLE* softkey is clicked.

If a table is edited that is stored on the hard disk of the measuring instrument but is not currently enabled, the changes will not be visible until it has been saved (*SAVE TABLE* softkey) and then enabled.

### HEADER/VALUES

The *HEADER/VALUES* softkey sets the focus of the edit option either to the entries in the table or to the table header.

#### Editing table header (*HEADER*):

Overwriting saved tables can be avoided by changing the name of the table. A table name must not consist of more than eight characters.

```
Remote: CONF:CDP:CTABL:NAME "NEW_TAB"
```

#### Editing table entries (*VALUES*):

This means editing the actual data of the channel table. The following entries are available for each of the channels contained in the table (confirm an input using the units keys):

- TYPE: Channel type; the special channels are identified by name (PICH, RRI, DATA, ACK or DRC). All inactive channels have the entry CHAN.
- CHAN.SF: The channel number and the spreading factor are predetermined by the channel type.
- SYMBOL RATE: Symbol rate with which the channel is transmitted. It depends directly on the spreading factor of the channel (see Table 18) and

therefore cannot be edited.

- MAPPING:** Specifies whether the channel is active on the I or Q branch. This entry is also predetermined by the channel type.
- ACTIVITY:** Activity specifies the half slot in which the channel is active (1) or inactive (0). . 16 digits can be entered. The number is interpreted in binary format and entered in decimal format by means of the parser.
- STATUS:** Status of the channel (active/inactive). When a change of channel status occurs, a channel that has been entered in the table can be hidden in the code domain power analysis without having to remove the corresponding entry from the table. Only channels with an "active" channel status are used for the CDP analysis. STATUS has priority over ACTIVITY.

```
Remote: CONF:CDP:CTAB:DATA 0,4,0,0,65535,0,1,0,1,
                               4,0,0,43690,0,1,0, 2,2,2,1,65535,0,1,0
                               'Selects PICH 0.16 on I with full
                               activity, RRI 0.16 on I active in every
                               even-numbered half slot and DATA 2.4 on Q
                               with full activity disabled.
                               CONF:CDP:CTAB:COMM
                               'Comment for new table
```

### ADD SPECIAL

The PICH pilot channel is always contained in the channel table. The *ADD SPECIAL* softkey allows additional channels to be added to the channel table.

INSERT LINE	
PICH	Reverse Pilot Channel
RRI	Reverse Rate Indicator
DATA	Reverse Data Channel
DRC	Reverse Data Rate Control Channel
ACK	Reverse Acknowledgement Channel

**Fig. 35** Table of special channels

```
Remote: -- (integrated in command: CONF:CDP:CTAB:DATA)
```

### DELETE LINE

The *DELETE LINE* softkey deletes the selected line from the table.

```
Remote: ---
```

### SAVE TABLE

The *SAVE TABLE* softkey saves the table with its specified name.

#### NOTICE!

Editing channel models and saving them under the original name will result in the models being overwritten.

```
Remote: -- (automatic with remote control)
```

**SORT TABLE**

The *SORT TABLE* softkey sorts the table in ascending spreading factor order, and in ascending channel number order within the spreading factors.

Remote: --

IEC/IEEE bus command: :CONF:CDP:CTAB:REST

**NEW CHAN CONF TABLE**

The *NEW CHAN CONF TABLE* softkey opens a submenu that is identical to the one for the *EDIT CHAN CONF TABLE* softkey.

<a href="#">DEL CHAN CONF TABLE</a>
<a href="#">COPY CHAN CONF TABLE</a>
<a href="#">RESTORE STD TABLES</a>

Unlike *EDIT CHAN CONF TABLE*, however, only the pilot channel PICH is entered in the table with *NEW CHAN CONF TABLE*; the name of the table is similarly still undefined:

EDIT CHANNEL TABLE					
NAME:		RL_DATA			
COMMENT:		DO Reverse Link only Data Channel			
TYPE	CHAN.SF	SYMBOL RATE [ksp/s]	MAP- PING	ACTIVITY [0/1:Off/On in Halfslot]	STATUS
PICH	0.16	76.8	I	1111 1111 1111 1111	ACTIVE

Fig. 36 Creating a new channel configuration

**DEL CHAN CONF TABLE**

The *DEL CHAN CONF TABLE* softkey deletes the selected table. The currently active table in *CODE CHAN PREDEFINED* mode cannot be deleted.

Remote: CONF:CDP:CTAB:DEL

**COPY CHAN CONF TABLE**

The *COPY CHAN CONF TABLE* softkey copies the selected table. The system asks for the name under which you want to save the copy.

Remote: CONF:CDP:CTAB:COPY "CTAB2"

**RESTORE STD TABLES**

The *RESTORE STD TABLES* softkey restores the predefined channel tables including all of their values (see Chapter 4) to the state they were in when the instrument left the factory. In this way unintentional overwriting can be undone.

Remote: CONF:CDP:CTAB:REST

### 6.6.3 Configuration of the application firmware - Hotkey SETTING

The *SETTINGS* hotkey opens a submenu for setting the measurement parameters of the application firmware.

<a href="#">BAND CLASS</a>	
<a href="#">CAPTURE SETTINGS</a>	
	<a href="#">CAPTURE LENGTH</a>
	<a href="#">SET COUNT SET TO ANALYZE</a>
	<a href="#">SELECT CHANNEL</a>
	<a href="#">SELECT HALF SLOT</a>
<a href="#">CDP AVG</a>	
<a href="#">ORDER HADAM/BITRE</a>	
<a href="#">CODE DOM OVERVIEW</a>	
<a href="#">SELECT I/Q</a>	
<a href="#">CODE PWR ABS/REL</a>	
<a href="#">POWER REF TOT/PICH</a>	
<a href="#">LONG CODE I/Q</a>	
<a href="#">INACT CHAN THRESHOLD</a>	
<a href="#">OPERATION ACCESS/TRAFFIC</a>	
<a href="#">INVERT Q</a>	
<a href="#">SIDE BAND NORM / INV</a>	
<a href="#">NORMALIZE ON / OFF</a>	

#### BAND CLASS

The *BAND CLASS* softkey is a setting parameter for the RF measurements "adjacent channel power" and "spectrum emission mask".

All other softkeys configure the measurements in the code domain analyzer.

The *BAND CLASS* softkey allows entry of the frequency band used for the RF measurements "adjacent channel power" and "spectrum emission mask". The selection is made from a table in which the name of the band class is displayed.

The center frequency entry is not restricted by the selected band class.

BAND CLASS SELECTION	
Band Class 0 (800 MHz Band)	
✓ Band Class 1 (1900 MHz Band)	
Band Class 2 (TACS Band)	
Band Class 3 (JTACS Band)	
Band Class 4 (Korean PCS Band)	
Band Class 5 (450 MHz Band)	
Band Class 6 (2 GHz Band)	
Band Class 7 (700 MHz Band)	
Band Class 8 (1800 MHz Band)	
Band Class 9 (900 MHz Band)	
Band Class 10 (Secondary 800 MHz Band)	
Band Class 11 (400 MHz European PAMR Band)	
Band Class 12 (800 MHz PAMR Band)	
Band Class 14 (US PCS 1.9GHz Band)	
Band Class 15 (AWS Band)	

Fig. 37 Band class selection

The user can scroll in the table, and the entry currently being used is identified by a checkmark, while a bar indicates the selected entry; click ENTER to apply the value.

The numerical value is specified by means of the IEC/IEEE bus.

Remote: CONF:CDP: BCL <band\_class>

### CAPTURE SETTINGS

The *CAPTURE SETTING* opens a submenu to define the capture configuration and the selection of half slots and channel for the evaluation.

<a href="#">CAPTURE LENGTH</a>
<a href="#">SET COUNT SET TO ANALYZE</a>
<a href="#">SELECT CHANNEL</a>
<a href="#">SELECT HALF SLOT</a>

### CAPTURE LENGTH

The *CAPTURE LENGTH* softkey allows entry of the number of half slots to be acquired. The entry is always made as a multiple of the half slot. The range is from 2 to 70 for the R&S FSU, R&S FSQ analyzers and from 2 to 24 for the R&S FSP analyzer. For all evaluations that exhibit one value per half slot on the x-axis, the maximum value on the x-axis is the set *CAPTURE LENGTH* -1.

Remote: SENS:CDP:IQL 2..70 (2..24)

### SET COUNT, SET TO ANALYZE

This function offers the possibility for the R&S FSQ to capture up to 3684 half slots (more than 3 seconds) with a SINGLE SWEEP and then post process all the data with *SET TO ANALYZE*.

If the *SET COUNT* is set to 1 (default value), the device behaves as before and with the *CAPTURE LENGTH* the number of half slots can be set.

For R&S FSQ the *SET COUNT* can be adjusted in the range of 1...57. If the *SET COUNT* greater than 1 the *CAPTURE LENGTH* will be implicitly set to 64 half slots and become unavailable. The *SET COUNT* defines then how many SETS of 64 half slots shall be captured consecutively into the IQ RAM of the R&S FSQ.

With the *SET TO ANALYZE* softkey the set for which the results are calculated can be defined. The range is from 0... (*SET COUNT*-1).

Remote: SENS:CDP:SET:COUN 1..57 (FSQ)  
SENS:CDP:SET:VAL <numeric\_value>

### SELECT CHANNEL

A channel is selected using the *SELECT CHANNEL* softkey. All evaluations that consider results for a channel specify the results for the newly selected channel: POWER VS HALF SLOT, POWER VS SYMBOL, RESULT SUMMARY, BITSTREAM, SYMBOL CONSTELLATION and SYMBOL EVM.

In the evaluations *CODE DOM POWER*, *CODE DOM ERROR POWER* and *CHANNEL TABLE* (all on Screen A), the selected channel is marked red.

Channels are entered in decimal format. The entered value is always converted to spreading factor 16. Only <channel> is displayed in the input field.

Normally the code and spreading factor 16 are displayed in the function field above the diagrams.

If, however, the current channel table contains a concentrated channel to which the selected channel belongs, this concentrated channel together with the associated code number and spreading factor is displayed in the function field and highlighted in red in the respective evaluations.

The rotating wheel action depends on the evaluation on Screen A and is geared to the graphic display. In the case of CODE DOMAIN POWER and CODE DOMAIN ERROR POWER, it depends on whether the Hadamard or BitReverse order is active. (See the *ORDER* softkey.) It is always the adjacent channel that is selected with the rotating wheel. In the channel table, the rotating wheel is used to scroll through the list.

Entries made using the IEC/IEEE bus are generally referred to spreading factor 16.

Remote: SENS:CDP:CODE 0...15

### SELECT HALF SLOT

The *SELECT HALF SLOT* softkey is used to select a half slot. Half slots are entered in decimal format. Here the range is from 0 to (IQ capture length - 1) (see the *CAPTURE LENGTH* softkey). All evaluations that consider results for a half slot specify the results for the newly selected half slot. (CODE DOMAIN POWER, CODE DOMAIN ERROR POWER, CHANNEL TABLE, POWER vs. SYMBOL, COMPOSITE CONSTELLATION, RESULT SUMMARY, BITSTREAM, SYMBOL CONSTELLATION and SYMBOL EVM).

In the evaluations POWER vs. HALF SLOT, COMPOSITE EVM and PEAK CODE DOMAIN ERROR, the selected half slot is highlighted in red.

Remote: SENS:CDP:SLOT 0 ... (IQ\_CAPTURE\_LENGTH-1)

### CDP AVG

The CDP AVG softkey is available for the code domain evaluation. If the softkey is ON, the code domain power evaluation is averaged over all half slots. If averaging is active, *Half Slot: ALL* is visible in the function field above the CDP diagram. The averaged evaluation is a requirement of the standard and has a special averaging algorithm for the ACK. The default setting is OFF; the application then behaves in exactly the same way as 1xEV-DO BTS.

Remote: SENS:CDP:AVER ON | OFF

### ORDER HADAM/BITRE

The *ORDER HADAM/BITRE* softkey allows channel sorting to be defined for the CODE DOMAIN POWER and CODE DOMAIN ERROR POWER evaluations. With Hadamard order (softkey set to HADAM), the codes are sorted in ascending order. With BitReverse order (softkey set to BITRE), channels with concentrated codes are adjacent to each other since the code numbers are sorted in bit-reversed order. (See the CODE DOMAIN POWER and CODE DOMAIN ERROR POWER evaluations.)

Remote: SENS:CDP:ORD HAD | BITR

### CODE DOM OVERVIEW

The *CODE DOM OVERVIEW* softkey is available and can be enabled for the code domain power and code domain error-power measurements. If Overview mode is activated, Screen A always displays the I branch and Screen B the Q branch of the CDP and CDEP evaluation.

```
Remote: SENS:CDP:OVER ON | OFF
```

### SELECT I/Q

The I or Q branch to be evaluated is selected with the *SELECT I/Q* softkey. The I branch is selected following a preset.

```
Remote: SENS:CDP:MAPP I | Q
```

### CODE PWR ABS/REL

The *CODE PWR ABS/REL* softkey selects for the CODE DOMAIN POWER evaluation whether the y-values should be displayed as absolute (dBm) or relative (dB). In relative mode, the reference is either the total power or the pilot power.

```
Remote: CALC1:FEED "XPOW:CDP:RAT" (relative)
        CALC1:FEED "XPOW:CDP" (absolute)
```

### POWER REF TOT/PICH

The *POWER REF TOT/PICH* softkey determines the reference power for the relative power evaluations:

**TOT** For each half slot, all relative power values (*CDP RELATIVE* evaluation) are referred to the total power of the signal in the respective half slot.

**PICH** The reference power is that of the pilot channel in the corresponding half slot.

The default setting of the softkey is *TOT*.

```
Remote: SENS:CDP:PREF TOT | PICH
```

### TIME/PHASE ON/OFF

The *TIME/PHASE ON/OFF* softkey allows activation and deactivation of the timing and phase offset evaluation of the channels relative to the pilot. If the value of the softkey is OFF (default setting), dashes ('---') are entered in the channel occupancy table and in the Result Summary evaluation for timing and phase offset. If the softkey is ON, the evaluation will take place and the values will be displayed.

```
Remote: SENS:CDP:TPM ON | OFF
```

### LONG CODE I/Q

Using the *LONG CODE I/Q* softkeys, the long code masks of the mobile can be defined in hexadecimal form separately for the I and Q branch. The default setting is 0. The range is from 0 to 3FF FFFF FFFF.

```
Remote: SENS:CDP:LCOD:I '#H0' ... '#H3FFFFFFFFF'
        SENS:CDP:LCOD:Q '#H0' ... '#H3FFFFFFFFF'
```



### INACT CHAN THRESHOLD

The *INACT CHAN THRESHOLD* softkey allows entry of the minimum power which an individual channel must have compared to the total signal in order to be regarded as the active channel.

Channels below the specified threshold are regarded as "inactive".

The two measurements *COMPOSITE EVM* and *PEAK CODE DOM ERR*, which are specified as measurements on the total signal, are performed using the list of active channels. Distortions of these two measurements always occur when active channels are not detected as being active and unassigned codes are wrongly given the status of "occupied channel". *INACT CHAN THRESHOLD* can therefore be used to influence the results of the two measurements.

The default value is -40 dB, which should result in all channels being detected by the CDP analysis. If not all channels contained in the signal are detected automatically, *INACT CHAN THRESHOLD* must be decremented.

```
Remote: SENS:CDP:ICTR -100 dB ... 0 dB
```

### OPERATION ACCESS/TRAFFIC

With the softkeys *OPERATION ACCESS/TRAFFIC* the operation mode is set. This information is used for the channel search.

In *TRAFFIC* mode all channels (PICH/RRI/DATA/ACK and DRC) can exist. PICH and RRI are always in the signal. In *ACCESS* mode only PICH (always available) and DATA channel can exist.

The softkeys are a 1 out of 2 selection, one of both is always selected.

Default is *TRAFFIC*.

```
Remote: SENS:CDP:OPER ACC | TRAF
```

### INVERT Q ON/OFF

The *INVERT Q ON / OFF* softkey inverts the sign of the Q component of the signal. The default setting is *OFF*.

```
Remote: SENS:CDP:QINV OFF
```

### SIDEBAND NORM / INV

The *SIDEBAND NORM / INV* softkey chooses between measurement of the signal in a normal and an inverted spectrum.

**NORM** The normal position allows measurement of mobile station RF signals.

**INV** This is recommended for measurements on IF modules or components in the case of spectral inversion.

The default setting is *NORM*.

```
Remote: SENS:CDP:SBAN NORM|INV
```

**NORMALIZE ON / OFF**

The *NORMALIZE ON / OFF* softkey removes the DC offset from the signal. The default setting is OFF.

Remote: SENS:CDP:NORM OFF

**6.6.4 Frequency settings - *FREQ* key**

The *FREQ* key opens a submenu for changing the measurement frequency.

<a href="#">CENTER</a>
<a href="#">CF-STEPSIZE</a>
<a href="#">FREQUENCY OFFSET</a>

**CENTER**

The *CENTER* softkey opens the input window for manual entry of the center frequency.

The permissible input range of the center frequency is

$$\text{Minspan}/2 \leq f_{\text{center}} \leq f_{\text{max}} - \text{Minspan}/2$$

$f_{\text{center}}$  center frequency  
 Minspan smallest selectable span > 0 Hz (10 Hz)  
 $f_{\text{max}}$  maximum frequency

Remote: FREQ:CENT 100MHz

**CF-STEPSIZE**

*CF STEPSIZE* opens a submenu for setting incrementation of the center frequency. There is an option of entering the step size manually (*MANUAL* softkey) or using the current measurement frequency (*CENTER* softkey). The softkeys are described in the manual for the basic unit.

Remote: FREQ:CENT:STEP <numeric\_value>

**FREQUENCY OFFSET**

The *FREQUENCY OFFSET* softkey enables entry of an arithmetic frequency offset that is added to the frequency axis labelling. The range for the offset is -100 GHz to 100 GHz. The default setting is 0 Hz.

Remote: FREQ:OFFS 10 MHz

**6.6.5 Span settings - *SPAN* key**

The *SPAN* key is disabled for measurements in the code domain analyzer. For all other measurements (see *MEAS* key), the permissible span settings are explained for the measurement concerned. The associated menu corresponds to that of the measurement in the basic unit and is described in the manual for the basic unit.

## 6.6.6 Level settings - *AMPT* key

The *AMPT* key opens a submenu for setting the reference level.

<a href="#">REF LEVEL</a>
<a href="#">ADJUST REF LEVEL</a>
<a href="#">REF LEVEL OFFSET</a>
<a href="#">Y PER DIV</a>
<a href="#">REF VALUE POSITION</a>
<a href="#">RF ATTEN MANUAL</a>
<a href="#">RF ATTEN AUTO</a>

### REF LEVEL

The *REF LEVEL* softkey enables entry of the reference level. The entry is in dBm.

Remote: `DISP:WIND:TRAC:Y:RLEV -60dBm`

### ADJUST REF LEVEL

*ADJUST REF LEVEL* executes a routine for optimum matching of the reference level to the signal.

Remote: `SENS<1|2>:CDP:LEV:ADJ`

### REF LEVEL OFFSET

The *REF LEVEL OFFSET* softkey enables entry of an arithmetic level offset. This is added to the measured level irrespective of the selected unit. The y-axis scaling is changed accordingly.

The setting range is  $\pm 200$  dB in 0.1 dB increments.

Remote: `DISP:WIND:TRAC:Y:RLEV:OFFS -10dB`

### Y PER DIV

*Y PER DIV* sets the grid spacing on the y-axis for all diagrams in which this is possible.

Remote: `DISP:WIND<1|2>:TRAC<1..3>:Y:SCAL:PDIV`

### REF VALUE POSITION

*REF VALUE POSITION* allows entry of the position of the y-axis reference value on the axis (0 to 100%).

Remote: `DISP:WIND<1|2>:TRAC<1..3>:Y:SCAL:RPOS`

### RF ATTEN MANUAL

The *RF ATTEN MANUAL* softkey activates entry of attenuation independently of reference level.

If the specified reference level can no longer be set for the given RF attenuation, it is matched and the "Limit reached" message appears.

Remote: `INP:ATT 40 DB`

### RF ATTEN AUTO

The *RF ATTEN AUTO* softkey sets the RF attenuation automatically as a function of the set reference level

This ensures that the optimum RF attenuation desired by the user is always used.

*RF ATTEN AUTO* is the default setting.

```
Remote: INP:ATT:AUTO ON
```

### 6.6.7 Marker settings - MKR key

The *MARKER* key opens a submenu for the marker settings.

Markers are not available for *RESULT SUMMARY* and *CHANNEL TABLE* evaluations.

Up to four markers can be activated in all other evaluations and defined as markers or delta markers with the *MARKER NORM / DELTA* softkey.

The *MARKER 1-4* softkeys select and enable the particular marker.

*MARKER 1* is always the normal marker after it is enabled, while *MARKER 2* through *4* are delta markers referred to *MARKER 1* after they are enabled. The *MARKER NORM DELTA* softkey is used to transform these markers into markers with absolute measured value display. If *MARKER 1* is the active marker, *MARKER NORM / DELTA* is used to enable an additional delta marker.

Press the *MARKER 1-4* softkeys again to disable the selected marker.

```
Remote: CALC:MARK ON;
        CALC:MARK:X <value>;
        CALC:MARK:Y?
        CALC:DELT ON;
        CALC:DELT:MODE ABS|REL
        CALC:DELT:X <value>;
        CALC:DELT:X:REL?
        CALC:DELT:Y?
```

### ALL MARKER OFF

The *ALL MARKER OFF* softkey disables all markers (reference and delta markers). It also disables the functions and displays associated with the markers and delta markers.

```
Remote: CALC:MARK:AOFF
```

The parameters relating to an enabled marker are read out above the diagrams:

Marker 1 [T1]	-5.23 dB
SR 38.4 ksps	11.15

**Fig. 38** Marker field of diagrams

Apart from the channel power, which is displayed relative to the value specified under *POWER REF TOT/PICH*, the channel parameters are additionally specified. The meanings are as follows (for the channel assigned to the marker):

SR 38.4 ksps: Symbol rate of the channel (19.2 ksps for unassigned codes)  
 11.16: Walsh code number and spreading factor of the channel

The marker functions of the basic unit apply in the case of all other measurements not belonging to the code domain analyzer.

### 6.6.8 Changing instrument settings - *MKR* → key

The *MKR* → key opens a submenu for marker functions:

<a href="#">SELECT MARKER</a>
<a href="#">PEAK</a>
<a href="#">NEXT PEAK</a>
<a href="#">PEAK MODE MIN/MAX</a>
<a href="#">MARKER → PICH</a>

#### SELECT MARKER

The *SELECT MARKER* softkey selects the required marker in a data entry box. If the marker is disabled, it is enabled and can then be moved. The entry is numerical. Delta marker 1 is selected by entering '0'.

```
Remote:  CALC:MARK1 ON;
         CALC:MARK1:X <value>;
         CALC:MARK1:Y?
```

#### PEAK

The *PEAK* softkey sets the active marker or delta marker to the maximum/minimum of the associated trace.

If no marker was activated before opening the *MKR*-> menu, marker 1 is automatically enabled and the *PEAK* function is executed.

```
Remote:  CALC:MARK:MAX
         CALC:DELT:MAX
         CALC:MARK:MIN
         CALC:DELT:MAX
```

#### NEXT PEAK

The *NEXT PEAK* softkey sets the active marker or delta marker to the next lower maximum/minimum value of the associated trace. The search direction is specified by the setting in the *NEXT MODE LEFT / RIGHT* submenu.

```
Remote:  CALC:MARK:MAX:NEXT
         CALC:DELT:MAX:NEXT
         CALC:MARK:MIN:NEXT
         CALC:DELT:MIN:NEXT
```

#### PEAK MODE MIN/MAX

The *PEAK MODE MIN / MAX* softkey sets whether the peak search should determine the maximum or minimum value of the trace. The parameter affects the response of the *PEAK* and *NEXT PEAK* softkeys.

```
Remote:  --
```

**MARKER → PICH**

The *MARKER → PICH* softkey sets the marker to the pilot channel (channel number 0.32).

```
Remote: CALC<1|2>:MARK<1>:FUNC:PICH
        CALC<1|2>:MARK<1>:Y?
```

**6.6.9 Marker functions - MKR FCTN key**

The *MKR FCTN* key is disabled for all measurements of the code domain analyzer. For all other measurements of the R&S FS-K85, the softkeys associated with the menu are described in the manual for the basic unit.

**6.6.10 Bandwidth setting - BW key**

The *BW* key is disabled for all measurements of the code domain analyzer. For all other measurements of the R&S FS-K85, the softkeys associated with the menu are described in the manual for the basic unit.

**6.6.11 Measurement control - SWEEP key**

The menu of the *SWEEP* key contains options for switching between single measurement and continuous measurement, and also control of single measurements. For measurements in the spectral range, the measurement time for a sweep can also be set. All softkeys associated with the menu are described in the manual of the basic unit.

**6.6.12 Measurement selection - MEAS key**

The menu of the *MEAS* key contains all the measurements that can be selected on the R&S FS-K85 by pressing a key. The menu and its submenus are described in Chapter 6.

**6.6.13 Trigger settings - TRIG key**

The selectable trigger options depend on the measurement selected. For the code domain power analyzer, a free-run mode and a mode with the external even second clock trigger called for by the 1xEV-DO standard are possible. The trigger options for all other measurements are identical to those of the corresponding measurement in the basic unit. The associated softkeys are described in the manual for the basic unit.

**EXTERN**

With the softkey *EXTERN* the external trigger source can be selected. From firmware V2.60/3.60 on also the external trigger level can be adjusted in the range from 0.5V to 3.5V. The default value is 1.4V.

```
Remote: TRIG:SEQ:LEV:EXT <numeric_value>
```

### 6.6.14 Trace settings - *TRACE* key

The *TRACE* key opens the following submenu:

<a href="#">CLEAR/WRITE</a>
<a href="#">MIN HOLD</a>
<a href="#">AVERAGE</a>
<a href="#">VIEW</a>

#### **CLEAR/WRITE**

The *CLEAR/WRITE* softkey enables the Overwrite mode for the acquired measured values, i.e. the trace is rewritten for each sweep.

When the *CLEAR / WRITE* softkey is actuated, the instrument deletes the selected trace memory and restarts the measurement.

Remote: `DISP:WIND:TRAC:MODE WRIT`

#### **MAX HOLD**

The *MAX HOLD* softkey activates peak value detection.

With each sweep, the analyzer only adopts the new measured value in the saved trace data if it is larger than the previous one.

Pressing the *MAX HOLD* softkey a second time deletes the trace memory and starts peak value detection from the beginning again.

Remote: `DISP:WIND:TRAC:MODE MAXH`

#### **MIN HOLD**

The *MIN HOLD* softkey activates minimum value detection.

With each sweep, the analyzer only adopts the new measured value in the saved trace data if it is smaller than the previous one.

Pressing the *MIN HOLD* softkey a second time deletes the trace memory and starts minimum value detection from the beginning again.

Remote: `DISP:WIND:TRAC:MODE MINH`

#### **AVERAGE**

The *AVERAGE* softkey enables the trace averaging function. The average is formed over several sweeps. Averaging is performed as a function of the *AVG MODE LOG / LIN* setting on the logarithmized level values or the measured power/voltage values.

Averaging is restarted every time the *AVERAGE* softkey is pressed. The trace memory is cleared each time.

Remote: `DISP:WIND:TRAC:MODE AVER`

#### **VIEW**

The softkey *VIEW* freezes the trace.

Remote: `DISP:WIND:TRAC:MODE VIEW`

An AVERAGE, MAX HOLD or MIN HOLD is possible for measurements in the code domain analyzer.

With the Channel Occupancy Table and Result Summary evaluation, the channel configuration measured on the first sweep is retained for the trace statistics.

If the signal is reconfigured, the SINGLE SWEEP softkey (and, if necessary, the CONTINUOUS SWEEP softkey) must be pressed again.

The *RESULT SUMMARY* and *BITSTREAM* evaluations and the *CONSTELLATION* diagrams only support *CLEAR / WRITE* mode.

### SWEEP COUNT

The *SWEEP COUNT* softkey sets the number of sweeps used for averaging. The permissible range is 0 to 30000, though the following should be noted:

Sweep count = 0	means sliding averaging with averaging length of 10.
Sweep count = 1	means no averaging
Sweep count > 1	means averaging over the specified number of sweeps; in a continuous sweep the averaging changes to sliding averaging once this number has been reached.

The default is sliding averaging (sweep count = 0). The number of sweeps used for averaging is always equal to the averaging length of 10 for all active traces in the selected diagram.

Remote: SWE:COUN 64

### 6.6.15 Display lines - *LINES* key

The *LINES* key is disabled for all measurements of the code domain analyzer. The menu setting options for all other measurements are equivalent to those of the corresponding measurement in the basic unit. The respective softkeys are described in the manual for the basic unit.

### 6.6.16 Measurement screen settings - *DISP* key

The menu of the *DISP* key contains softkeys for configuring the measurement screen. The menus and softkey features are described in the manual of the basic unit.

### 6.6.17 Storing and loading instrument data - *FILE* key

The *FILE* menu is the same as that of the basic unit. All softkeys are described in the manual for the basic unit.



### 6.6.18 Preset of device - *PRESET* key

The *PRESET* key presets the device. The behavior is the same as of the basic unit and is described in the manual for the basic unit.

### 6.6.19 Calibration of device - *CAL* key

The menu *CAL* is the same as that of the basic unit. All softkeys are described in the manual for the basic unit.

### 6.6.20 Setup of device - *SETUP* key

The menu *SETUP* is the same as that of the basic unit. All softkeys are described in the manual for the basic unit. The usage of transducer factors is possible in the Code-Domain as well as in the RF measurements.

Using the FS-K9 "Measurements with Power Sensor" is also possible within that application. Therefore the FS-K9 must be installed and the option key must be entered, then in the sidemenu the softkey *POWERMETER* is available. For further details of the FS-K9 please refer to the FS-K9 software manual.

### 6.6.21 Printing - *HCOPY* key

The menu *HCOPY* is the same as that of the basic unit. All softkeys are described in the manual for the basic unit.

All keys on the front panel of the instrument that are not specifically mentioned are identical to those of the basic unit. The functions of the keys and the softkeys are described in the manual of the basic unit.

## 7 Remote Control Commands

This chapter describes the remote control commands for the application firmware.

The commands that also apply to the basic unit in *SPECTRUM* mode and the system settings are described in the operating manual for the analyzer.

### 7.1 CALCulate:FEED subsystem

The CALCulate:FEED subsystem selects the type of evaluation for the measured data. This corresponds to the selection of the result display in manual operation.

#### CALCulate<1|2>:FEED <string>

This command selects the measured data that will be displayed.

##### Parameters

<string>: = 'XPOW:CDP' |  
 'XPOW:CDP:RAT' |  
 'XPOW:CDEP' |  
 'XTIM:CDP:MACCuracy' |  
 'XTIM:CDP:PVSLOT' |  
 'XTIM:CDP:PVSYmbol' |  
 'XTIM:CDP:BSTReam' |  
 'XTIM:CDP:ERR:SUMM' |  
 'XTIM:CDP:ERR:CTABLE' |  
 'XTIM:CDP:ERR:PCDomain' |  
 'XTIM:CDP:SYMB:CONST' |  
 'XTIM:CDP:SYMB:EVM' |  
 'XTIM:CDP:COMP:CONST'

The meanings of the string parameters are as follows:

'XPOW:CDP'	Result display of code domain power (absolute) in bar graph (CALCulate<1>)
'XPOW:CDP:RAT'	Result display of code domain power ratio (relative) in bar graph (CALCulate<1>)
'XPOW:CDEP'	Result display of code domain error power in bar graph (CALCulate<1>)
'XTIM:CDP:ERR:SUMM'	Tabular display of results (CALCulate2)
'XTIM:CDP:ERR:CTABLE'	Display of channel occupancy table (CALCulate<1>)
'XTIM:CDP:ERR:PCDomain'	Result display of peak code domain error (CALCulate2)
'XTIM:CDP:MACCuracy'	Result display of composite EVM (CALCulate2)
'XTIM:CDP:PVSLOT'	Result display of power versus half slot (CALCulate2)
'XTIM:CDP:PVSYmbol'	Result display of power versus symbol (CALCulate2)

'XTIM:CDP:BSTReam'	Result display of bit stream (CALCulate2)
'XTIM:CDP:SYMB:CONST'	Result display of symbol constellation (CALCulate2)
'XTIM:CDP:SYMB:EVM'	Result display of error vector magnitude (CALCulate2)
'XTIM:CDP:COMP:CONST'	Result display of composite constellation (CALCulate2)

**Example**

```

INST:SEL MDO
'Activate 1xEV-DO MS
INIT:CONT OFF
'Select single sweep
CALC2:FEED 'XTIM:CDP:MACC'
'Select COMP EVM evaluation
INIT;*WAI
'Start measurement with synchronization
TRAC? TRACE2
'Query COMP EVM data

```

**Characteristics**

\*RST value: 'XPOW:CDP:RAT' (CALC<1>)  
'XTIM:CDP:ERR:SUMM' (CALC<2>)  
SCPI: conform



Code domain power measurements are always shown in split screen mode and the allocation of the evaluation to the measurement window is fixed. The necessary or allowed numerical suffix in CALCulate is therefore specified in brackets in every evaluation.

To activate the Overview mode for Code Domain Power and Code Domain Error Power, you must use the CDP:OVER ON command.

If you then switch to an evaluation different from these two (e.g. the Channel Occupancy table), you leave Overview mode and the evaluation you used last is restored on the other screen.

## 7.2 CALCulate:LIMit:SPECtrum Subsystem

The CALCulate:LIMit:SPECtrum subsystem defines the limit check for spectral measurements.

### CALCulate:LIMit:ESpectrum:CHECK:X?;Y?

These commands query the worst fail position.

#### Example

```
INST:SEL MDO
'Activate 1xEV-DO MS
INIT:CONT OFF
'Select single sweep
CONF:CDP:MEAS ESP
'Select spectrum emission mask measurement
INIT;*WAI
'Start measurement with 'synchronization
CALC:LIM:ESP:CHEC:X?;Y?
'Query result of worst fail position
```

#### Characteristics

\*RST value: --  
SCPI: device-specific

### CALCulate:LIMit:ESpectrum:MODE AUTO | USER

This command enables and disables automatic selection of the limit line in the spectrum emission mask measurement. The limit lines normally depend on the selected band class. (Command CONF:CDP:BCL).

#### Parameters

**AUTO** The limit line sets itself according to the measured channel power.  
**USER** Query only, user-defined limit lines are enabled  
 (see the details of limit lines in the manual for the instrument).

#### Example

```
INST:SEL MDO
'Activate 1xEV-DO MS
INIT:CONT OFF
'Select single sweep
CONF:CDP:BCL 1
'Select band class 1, 1900 MHz
CONF:CDP:MEAS ESP
'Select spectrum emission mask measurement
CALC:LIM:ESP:MODE AUT
'Activates automatic selection of limit line
INIT;*WAI
```

```
'Start measurement with synchronization  
CALC:LIM:FAIL?  
'Query result of limit check
```

**Characteristics**

\*RST-Wert: AUTO  
SCPI: device-specific

---

**CALCulate:LIMit:ESpectrum:REStore**

This command restores the standard limit lines for spectrum emission mask measurement. All changes to the standard limit lines are thus lost and the as-delivered state of these limit lines is restored.

**Example**

```
INST:SEL MDO  
'Activate 1xEV-DO MS  
  
CALC:LIM:ESP:REST  
'Resets spectrum emission mask limit lines to default
```

**Characteristics**

\*RST value: --  
SCPI: device-specific

This command is an event, so it has neither a query function nor an \*RST value.

## 7.3 CALCulate:MARKer - Subsystem

**CALCulate<1|2>:MARKer<1>:FUNCTion:CDPower:RESult? SLOt | PTOTal | PPICh | PRRI | RHO | MACCuracy | PCDerror | ACTive | FERRor | FERPpm | DRPich | RHOverall | CERRor | TFRame | IQOFFset | IQIMbalance | SRATe | CHANnel | SFACTor | TOFFset | POFFset | CDPabsolute | CDPRelative | EVMRms | EVMPeak**

This command queries the measured and calculated values of the code domain power analysis. The channel results are provided for the channel to which the code selected by means of the `CDPower:CODE` command belongs.

### Parameters

Global results of selected half slot:		Global results of all half slots:	
SLOt	Half-slot-number		
PTOTal	Total power in dBm	FERRor	Frequency error in Hz
PPICh	Pilot power in dBm	FERPpm	Frequency error in ppm
PRRI	RRI power in dBm	DRPich	Delta RRI/PICH in dB
RHO	RHO	RHOverall	RHO overall
MACCuracy	Composite EVM in %	TFRame	Trigger to frame
PCDerror	Peak code domain error in dB	CERRor	Chip rate error in ppm
IQIMbalance	IQ imbalance in %	IQOFFset	IQ Offset in %
ACTive	Number of active channels		
<b>Channel results</b>			
SRATe	Symbol rate in ksps	TOFFset	Timing offset in s
CHANnel	Channel number	POFFset	Phase offset in rad
SFACTor	Spreading factor of channel		
CDPRelative	Channel Power relative in dB	CDPabsolute	Channel power absolute in dBm (relative to total or PICH power (s. command <code>CDP:PREF</code> ))
EVMRms	ErrorVectorMagnitudeRMSin %	EVMPeak	Error vector magnitude peak in %



The PRRI value returns -200 dB if there is no RRI channel for the selected half slot. In this case, the DRPich value also shows -200 dB.

The trigger to frame (TFRame) value returns a '9' if the trigger is set to FREE RUN. The timing/phase offset values (TOFFset/POFFset) return a '9' if the timing and phase offset measurement is switched off (see `CDP:TPM`) or the number of active channels exceeds 50. The mapping of the selected channel also displayed in the Result Summary can be read out using the command `[SENSE]:CDPower:MAPPING?`

**Example**

```

INST:SEL MDO
'Activate 1xEV-DO MS, implicit are CDP relative on Screen A
and Result Summary active on Screen B
INIT:CONT OFF
'Select single sweep
INIT;*WAI
'Start measurement with synchronization
CALC:MARK:FUNC:CDP:RES? PTOT
'Read out total power
CDP:SLOT 2
'Selects half slot 2
CDP:CODE 11
'Select code number 11
CALC:MARK:FUNC:CDP:RES? EVMR
'Read out EVM RMS of code with number 11 in half slot 2

```

**Characteristics**

\*RST value: -  
 SCPI: device-specific

---

**CALCulate<1|2>:MARKer<1>:FUNCtion:PICH**

This command sets marker1 to channel 0.16.

**Example**

```

INST:SEL MDO
'Activate 1xEV-DO MS, implicit are CDP relative on Screen A
and Result Summary active on Screen B
INIT:CONT OFF
'Select single sweep
INIT;*WAI
'Start measurement with synchronization
CALC:MARK:FUNC:PICH
'Activate marker and set to pilot
CALC:MARK:Y?
'Query value of the CDP rel. of the PICH

```

**Characteristics**

\*RST value:-  
 SCPI: device-specific

This command is an event, so it has neither an \*RST value nor a query function.

## 7.4 CALCulate:STATistics subsystem

The CALCulate:STATistics subsystem controls the statistical measurement functions in the instrument. The measurement window cannot be selected for these measurement functions. The numerical suffix is ignored accordingly with CALCulate.

### CALCulate:STATistics:CCDF[:STATe] ON | OFF

This command enables and disables measurement of the complementary cumulated distribution function (CCDF).

#### Example

```
CALC:STAT:CCDF ON
```

#### Characteristics

\*RST value: OFF

SCPI: device-specific

### CALCulate:STATistics:NSAMples 100 ... 1E9

This command sets the number of measurement points for the statistical measurement functions.

#### Example

```
CALC:STAT:NSAM 5000
```

#### Characteristics

\*RST value: 100000

SCPI: device-specific

### CALCulate:STATistics:RESult? MEAN | PEAK | CFACTor | ALL

This command reads out the results of statistical measurements from a recorded trace.

#### Parameters

The desired result is selected by means of the following parameters:

MEAN	Mean (rms) power in dBm measured in the period of observation
PEAK	Peak power in dBm measured in the period of observation
CFACTor	Determined CREST factor (i.e. ratio of peak power to mean power) in dB
ALL	Results of all three named measurements, separated by a comma: <mean power>,<peak power>,<crest factor>

#### Example

```
CALC:STAT:RES? ALL
```

'Reads out all three measurement results.'

Example of reply string: 5.56,19.25,13.69 i.e. mean power:  
5.56 dBm, peak power 19.25 dBm, CREST factor 13.69 dB



**Characteristics**

\*RST value: --  
 SCPI: device-specific

**CALCulate:STATistics:SCALE:Y:LOWer 1E-6 ...0.1**

This command defines the lower limit for the y-axis of the diagram in statistical measurements. Since probabilities are plotted on the y-axis, the entered numerical values have no units.

**Example**

```
CALC:STAT:SCAL:Y:LOW 0.001
```

**Characteristics**

\*RST value: 1E-6  
 SCPI: device-specific

**CALCulate:STATistics:SCALE:Y:UPPer 1E-5 ...1.0**

This command defines the upper limit for the y-axis of the diagram in statistical measurements. Since probabilities are plotted on the y-axis, the entered numerical values have no units.

**Example**

```
CALC:STAT:SCAL:Y:UPP 0.01
```

**Characteristics**

\*RST value: 1.0  
 SCPI: device-specific

## 7.5 CONFigure:CDPower subsystem

This subsystem contains the commands for the selection and configuration of measurements in the 1xEV-DO application firmware. Only the numerical suffix 1 is allowed for CONFigure. Further settings for code domain power analysis can be found under the :[SENSe]:CDPower command. Further settings for spectrum emission mask measurement can be found under the CALCulate:LIMit:ESpectrum command.

**CONFigure:CDPower:BCLass 0...15**

This command selects the band class.

Band class	Name
0	800 MHz band
1	1900 MHz band
2	TACS band
3	JTACS band

4	Korean PCS band
5	450 MHz band
6	2 GHz band
7	700 MHz band
8	1800 MHz band
9	900 MHz band
10	Secondary 800 MHz band
11	400 MHz European PAMR band
12	800 MHz PAMR band
14	US PCS 1.9GHz band
15	AWS band

**Example**

```

INST:SEL MDO
'Activate 1xEV-DO MS
INIT:CONT OFF
'Select single sweep
CONF:CDP:BCL 1
'Select band class 1, 1900 MHz

```

**Characteristics**

\*RST value: 0  
 SCPI: device-specific

**CONFigure:CDPower:CTABLE:CATalog?**

This command queries the names of all the channel tables for 1xEV-DO MS stored on the hard disk.

The syntax of the output format is as follows:

<Sum of sizes of all subsequent files>,<Spare capacity on hard disk>,  
 <1st file name>,<1st file size>,<2nd file name>,,<2nd file size>,,...,<nth file  
 name>,,<nth file size>,,

**Example**

```

INST:SEL MDO
'Activate 1xEV-DO MS
CONF:CDP:CTAB:CAT?
'Query catalog

```

**Characteristics**

\*RST value: --  
 SCPI: device-specific

**CONFigure:CDPower:CTABLE:COMment <string>**

This command defines a comment on the selected channel table.

Before using this command, you must set the name of the channel table using the CONF:CDP:CTAB:NAME command and enter a valid channel table with CONF:CDP:CTAB:DATA.

**Example**

```

INST:SEL MDO
'Activate 1xEV-DO MS
CONF:CDP:CTAB:NAME 'NEW_TAB'
'Select table to edit

CONF:CDP:CTAB:COMM
'Comment for NEW_TAB'"

```

**Characteristics**

\*RST value: ""  
 SCPI: device-specific

**CONFigure:CDPower:CTABLE:COPY <file\_name>**

This command copies one channel table to another. You select the channel table you want to copy using the CONF:CDP:CTAB:NAME command.

**Parameters**

<file\_name> ::= Name of new channel table

**Example**

```

INST:SEL MDO
'Activate 1xEV-DO MS

CONF:CDP:CTAB:NAME 'CTAB_1'
'Select table to edit

CONF:CDP:CTAB:COPY 'CTAB_2'
'Copies CTAB_1 to C_TAB2

```

**Characteristics**

\*RST value: --  
 SCPI: device-specific

The name of the channel table may consist of up to eight characters. This command is an event, so it has neither an \*RST value nor a query function.

**CONFigure:CDPower:CTABLE:DATA 0..5, 2..4, 0..15, 0..1, 0..65535, 0, 0 | 1, <numeric\_value>...**

This command defines a channel table. The whole table is defined in one operation. The inactive channels (INActive) do not have to be defined. Eight values are specified for a line of a table.

<Channel type>, <Code class>, <Code number>, <Mapping>, <Activity>, <Reserved1>, <Status>, <Reserved2>, ....

Channel type: The channel type is coded by numbers as follows:  
 0 = PICH  
 1 = RRI  
 2 = DATA

	3 = ACK
	4 = DRC
	5 = INACTIVE
Code class:	2...4
Code number:	0...15
Mapping 0	= I branch
1	= Q branch
Activity:	0..65535 (decimal)
	The decimal number interpreted as a binary number in 16 bits, determines the half slot in which the channel is active (value 1) or inactive (value 0).
	<b>Example:</b>
	65535 decimal = 1111 1111 1111 1111 bin. (e.g. DATA)
	Channel is active in each half slot
	43690 decimal = 1010 1010 1010 1010 bin. (e.g. RRI)
	Channel is active in each half slot
	24576 decimal = 0110 0000 0000 0000 bin. (e.g. DRC)
	Channel is active in half slot 1 and 2
Reserved 1:	Always 0 (reserved)
Status:	0: inactive, 1: active can be used in a setting command to disable a channel temporarily
Reserved 2:	Always 0 (reserved)

Before using this command, you must set the name of the channel table using the `CONF:CDP:CTAB:NAME` command. Only valid 1xEV-DO MS channels are accepted as active.

### Example

```
INST:SEL MDO
'Activate 1xEV-DO MS
CONF:CDP:CTAB:NAME 'NEW_TAB'
'Select table to edit

CONF:CDP:CTAB:DATA 0,4,0,0,65535,0,1,0,1,4,0,0,43690,0,1,0,
2,2,2,1,65535,0,1,0
'Selects PICH 0.16 on I with full activity, RRI 0.16 on I in each
even-numbered half slot, and DATA 2.4 on Q with full activity
```

### Characteristics

\*RST value: -  
SCPI: device-specific

### CONFigure:CDPower:CTABLE:DELeTe

This command deletes the selected channel table. You select the channel table you want to delete using the `CONF:CDP:CTAB:NAME` command.

### Example

```
INST:SEL MDO
'Activate 1xEV-DO MS
```

```
CONF:CDP:CTAB:NAME 'CTAB_2'
'Select table to edit
```

```
CONF:CDP:CTAB:DEL
'Deletes CTAB_2
```

### Characteristics

\*RST value: --  
SCPI: device-specific

This command is an event, so it has neither an \*RST value nor a query function.

---

### CONFigure:CDPower:CTABLE:NAME <file\_name>

This command selects a channel table to edit or create. It is *not* used for analysis. In this context, see commands CONF:CDP:CTAB:STAT and CONF:CDP:CTAB:SEL.

### Example

```
INST:SEL MDO
'Activate 1xEV-DO MS
CONF:CDP:CTAB:NAME 'NEW_TAB'
'Select table to edit
```

### Characteristics

\*RST value: ""  
SCPI: device-specific

### CONFigure:CDPower:CTABLE:RESTore

This command restores the "predefined channel tables" to the state they were in when the instrument was supplied. In this way unintentional overwriting of the channel tables can be undone.

### Example

```
INST:SEL MDO
'Activate 1xEV-DO MS
CONF:CDP:CTAB:REST
'Restore table
```

### Characteristics

\*RST value: --  
SCPI: device-specific

This command is an event, so it has neither an \*RST value nor a query function.

---

**CONFigure<1>:CDPower:CTABle[:STATe] ON | OFF**

This command enables and disables the channel table. Enable results in a standard channel table which contains only the PICH being saved as "DEFAULT" and enabled. After the channel table called "DEFAULT" has been enabled, another channel table can be selected with the `CONF:CDP:CTABle:SElect` command.



You must always enable the "DEFAULT" channel table first with the `CONF:CDP:CTAB:STAT` command and then use the `CONF:CDP:CTAB:SElect` command to select the channel table you require.

**Example**

```
INST:SEL MDO
'Activate 1xEV-DO MS, implicit are CDP relative on Screen A
and Result Summary active on Screen B
INIT:CONT OFF
'Select single sweep
INIT;*WAI
'Start measurement with synchronization so that channel table
can be enabled
CONF:CDP:CTAB ON
'Use predefined channel table
'Select channel table
INIT;*WAI
'Start measurement with synchronization
```

**Characteristics**

\*RST value: OFF  
SCPI: device-specific

**CONFigure<1>:CDPower:CTABle:SElect <string>**

This command selects a predefined channel table file. Before using this command, you must first enable the "DEFAULT" channel table with the `CONF:CDP:CTAB ON` command.

**Example**

```
INST:SEL MDO
'Activate 1xEV-DO MS, implicit are CDP relative on Screen A
and Result Summary active on Screen B
INIT:CONT OFF
'Select single sweep
INIT;*WAI
'Start measurement with synchronization so that channel table
can be enabled
CONF:CDP:CTAB ON
'Use predefined channel table
```

```

CONF:CDP:CTAB:SEL 'CTAB_1'
'Select channel table

INIT;*WAI
'Start measurement with synchronization

```

### Characteristics

\*RST value: "RECENT"  
 SCPI: device-specific

## CONFigure<1>:CDPower:MEASurement POver | ACLR | ESpectrum | OBANdwith | OBWidth | CDPower | CCDF

This command selects the measurement of Application FS-K85, 1xEV-DO mobile station tests. The predefined settings of the different measurements are described in Chapter 6.

### Parameters

POWer	Channel power measurement (1xEV-DO reverse standard) with predefined settings
ACLR	Adjacent channel power measurements (1xEV-DO reverse standard) with predefined settings
ESpectrum	Check of signal power (spectrum emission mask)
OBANdwith   OBWidth	Measurement of occupied bandwidth
CDPower	Code domain analyzer measurement
CCDF	Measurement of the complementary cumulative distribution function (signal statistics measurement)

### Example

```

INST:SEL MDO
'Activate 1xEV-DO MS

INIT:CONT OFF
'Select single sweep

CONF:CDP:MEAS POW
'Select channel power measurement

INIT;*WAI
'Start measurement with synchronization

```

### Characteristics

\*RST value: CDPower  
 SCPI: device-specific

## 7.6 INSTrument Subsystem

The INSTrument subsystem selects the operating mode of the instrument either by means of text parameters or by means of permanently assigned numbers.

### INSTrument:NSElect 1 | 15

This command toggles between the operating modes by means of numbers.

#### Parameters

- 1: Spectral analysis mode
- 15: 1xEV-DO MS mode

#### Example

```
INST:NSEL 15  
'Activate 1xEV-DO MS
```

#### Characteristics

\*RST value: 1  
SCPI: conforming

---

### INSTrument[:SElect] SANalyzer | MDO

This command toggles between the operating modes by means of text parameters.

Selecting 1xEV-DO MS (MDO) sets the instrument to a defined state. The preset values are described in Chapter 2 in the section entitled "Default settings in the 1xEV-DO MS operating mode".

#### Example

```
INST MDO  
'Activate 1xEV-DO MS
```

#### Characteristics

\*RST value: SANalyzer  
SCPI: conforming



## 7.7 SENSe:CDPower subsystem

This subsystem sets the parameters for code domain measurement mode. The numerical suffix for SENSe<1|2> is meaningless for this subsystem.

### [SENSe:]CDPower:AVERage ON | OFF

This command is used to enable averaging of the CDP evaluation over all recorded half slots. The command is only available in the CDP measurement.

#### Example

```
INST:SEL MDO
'Activate 1xEV-DO MS, implicit are CDP relative on Screen A
and Result Summary active on Screen B

CDP:AVER ON
'Activate CDP average

INIT;*WAI
'Start measurement with synchronization
```

#### Characteristics

\*RST value: OFF  
SCPI: device-specific

---

### [SENSe:]CDPower:CODE 0 ... 15

This command selects the code number. The maximum value is 15.

#### Example

```
INST:SEL MDO
'Activate 1xEV-DO MS, implicit are CDP relative on Screen A
and Result Summary active on Screen B

INIT:CONT OFF
'Select single sweep

CDP:CODE 11
'Select code number 11

INIT;*WAI
'Start measurement with synchronization
```

#### Characteristics

\*RST value: 0  
SCPI: device-specific

---

### [SENSe:]CDPower:ICTReshold -100 dB ...0 dB

This command sets the threshold above which a channel is regarded as active. The level refers to total signal power.

**Example**

```

INST:SEL MDO
'Activate 1xEV-DO MS, implicit are CDP relative on Screen A
and Result Summary active on Screen B

INIT:CONT OFF
'Select single sweep

CDP:ICTR -10DB
'Threshold at -10dB

INIT;*WAI
'Start measurement with synchronization

```

**Characteristics**

\*RST value: -40dB  
 SCPI: device-specific

---

**[SENSe:]CDPower:IQLength FSU/FSQ: 4..70, FSP: 4..24**

This command sets the capture length (IQ Capture Length) in half slots. The range is from 4 to 70 for the R&S FSU, R&S FSQ analyzers and from 4 to 24 for the R&S FSP analyzer.

**Example**

```

INST:SEL MDO
'Activate 1xEV-DO MS, implicit are CDP relative on Screen A
and Result Summary active on Screen B

INIT:CONT OFF
'Select single sweep

CDP:IQL 8
'8 half-slot capture length

INIT;*WAI
'Start measurement with synchronization

```

**Characteristics**

\*RST value: 6  
 SCPI: device-specific

---

**[SENSe:]CDPower:LCODE:I '#H0' ... '#H3FFFFFFFFF'**

This command defines the mask of the long code in hexadecimal format for the I branch.

**Example**

```

INST:SEL MDO
Activate 1xEV-DO MS, implicit are CDP relative on Screen A
and Result Summary active on Screen B

```

```

INIT:CONT OFF
'Select single sweep

TRIG:SOUR EXT
'Select external trigger source

CDP:LCOD:I '#HF'
'Define long code mask

INIT;*WAI"
'Start measurement with synchronization

```

**Characteristics**

\*RST value: '#H0'  
 SCPI: device-specific

---

**[SENSe:]CDPower:LCODE:Q '#H0' ... '#H3FFFFFFFFF'**

This command defines the mask of the long code in hexadecimal format for the I branch.

**Example**

```

INST:SEL MDO
Activate 1xEV-DO MS, implicit are CDP relative on Screen A
and Result Summary active on Screen B

INIT:CONT OFF
'Select single sweep

TRIG:SOUR EXT
'Select external trigger source

CDP:LCOD:Q '#HF'
'Define long code mask

INIT;*WAI
'Start measurement with synchronization

```

**Characteristics**

\*RST value: '#H0'  
 SCPI: device-specific

---

**[SENSe:]CDPower:LEVel:ADJust**

This command initiates automatic setting of the RF attenuation and IF gain to the level of the applied signal. The instrument is put into *RF ATTEN MANUAL* mode to optimize RF attenuation and IF gain independently of each other. This mode is retained even after the mode has changed from 1xEV-DO MS to SPECTRUM.

**Example**

```

INST:SEL MDO
'Activate 1xEV-DO MS, implicit are CDP relative on Screen A
and Result Summary active on Screen B

INIT:CONT OFF
'Select single sweep

CDP:LEV:ADJ
'Start automatic level setting

INIT;*WAI
'Start measurement with synchronization

```

**Characteristics**

\*RST value: -  
 SCPI: device-specific

This command is an event, so it has neither an \*RST value nor a query function.

---

**[SENSe:]CDPower:MAPPING I | Q**

This command selects whether the I or Q branch is to be evaluated.

**Example**

```

INST:SEL MDO
'Activate 1xEV-DO MS, implicit is I branch is selected

INIT:CONT OFF
'Select single sweep

CDP:MAPP Q
'Selects Q branch

INIT;*WAI
'Start measurement with synchronization

```

**Characteristics**

\*RST value: I  
 SCPI: device-specific

---

**[SENSe:]CDPower:NORMALize ON | OFF**

This command enables and disables elimination of the IQ offset.

**Example**

```

INST:SEL MDO
'Activate 1xEV-DO MS, implicit are CDP relative on Screen A
and Result Summary active on Screen B

INIT:CONT OFF
'Select single sweep

CDP:NORM OFF
'Elimination of IQ offset disabled

```

```
INIT;*WAI
'Start measurement with synchronization
```

#### Characteristics

```
*RST value: OFF
SCPI: device-specific
```

---

#### [SENSe:]CDPower:OPERation ACCess | TRAFfic

This command is used to set the operation mode. This information is used for the channel search. In TRAFFIC mode all channels (PICH/RRI/DATA/ACK and DRC) can exist. PICH and RRI are always in the signal. In ACCESS mode only PICH (always available) and DATA channel can exist.

#### Example

```
INST:SEL MDO
'Activate 1xEV-DO MS, implicit are CDP relative on Screen A
and Result Summary active on Screen B

CDP:OPER ACC
'ACCESS operation is set
```

#### Characteristics

```
*RST value: TRAFfic
SCPI: device-specific
```

---

#### [SENSe:]CDPower:ORDer HADamard | BITReverse

This command sets the order of the code domain evaluation. The codes are sorted either in Hadamard order or in BitReverse order.

#### Example

```
INST:SEL MDO
'Activate 1xEV-DO MS, implicit are CDP relative on Screen A
and Result Summary active on Screen B

INIT:CONT OFF
'Select single sweep

INIT;*WAI
'Start measurement with synchronization

CDP:ORD HAD
'Hadamard order

TRAC? TRACE2
'Read out CDP in Hadamard order

CDP:ORD BITR
'BitReverse order
```

```
TRAC? TRACE2
'Read out CDP in BitReverse order
```

### Characteristics

\*RST value: HADamard  
SCPI: device-specific

---

## [SENSe:]CDPower:OVERview ON | OFF

This command can be enabled by means of ON when either the code domain power or the code domain error-power evaluation is active. (See the command CALC1:FEED.) In Overview mode, the I branch of the signal is normally displayed on Screen A and the Q branch of the signal on Screen B with the CDP/CDEP. The branches can be read out separately by means of TRAC:DATA? TRACE1 and TRAC:DATA? TRACE2.

The previous evaluations become active again when you exit Overview mode.

If an evaluation other than code domain power or code domain error power is selected when Overview mode is active, you exit Overview mode and the previous evaluation is reset on the other screen.

### Example

```
INST:SEL MDO
'Activate 1xEV-DO MS, implicit are CDP relative on Screen A
and Result Summary active on Screen B
INIT:CONT OFF
'Select single sweep

INIT;*WAI
'Start measurement with synchronization

CDP:OVER ON
'Activate Overview mode CDP relative on Screen A I branch CDP
relative on Screen B Q branch

TRAC? TRACE1
'Read out CDP relative of I branch

TRAC? TRACE2
'Read out CDP relative of Q branch

CDP:OVER OFF
'Disable Overview mode: CDP relative on Screen A and Result
Summary active on Screen B
```

### Characteristics

\*RST value: OFF  
SCPI: device-specific

---

**[SENSe:]CDPower:PREFerence TOTal | PICH**

This command sets the reference for the relative CDP measured values to the total power or the PICH power.

**Example**

```
INST:SEL MDO
'Activate 1xEV-DO MS, implicit are CDP relative on Screen A
and Result Summary active on Screen B

INIT:CONT OFF
'Select single sweep

CDP:PREF PICH
'Reference is PICH power

INIT;*WAI
'Start measurement with synchronization
```

**Characteristics**

\*RST value: TOTal  
SCPI: device-specific

---

**[SENSe:]CDPower:QINVert ON | OFF**

This command inverts the sign of the signal Q component.

**Example**

```
INST:SEL MDO
'Activate 1xEV-DO MS, implicit are CDP relative on Screen A
and Result Summary active on Screen B

INIT:CONT OFF
'Select single sweep

CDP:QINV ON
'Enable invert Q component

INIT;*WAI
'Start measurement with synchronization
```

**Characteristics**

\*RST value: OFF  
SCPI: device-specific

---

**[SENSe:]CDPower:SET:COUNT 1 ... 57**

If the SET COUNT is set to 1 (default value), the device behaves as normal and with the command CDPower:IQLength (IQ-Capture-Length) the number of half slots can be set.

For R&S FSQ the SET COUNT can be adjusted in the range of 1...57. Is the SET COUNT greater than 1 the IQ-Capture-Length will be implicitly set to 64 half slots

and become unavailable. The SET COUNT defines then how many SETS of 64 half slots shall be captured consecutively into the IQ RAM of the R&S FSQ.

This command is only available on R&S FSQ.

### Example

```
INST:SEL MDO
'Activate 1xEV-DO MS, implicit are CDP relative on Screen A
and Result Summary active on Screen B

INIT:CONT OFF
'Select single sweep

CDP:SET:COUN 12
'Select 12 sets of 64 half slots on R&S FSQ

INIT;*WAI
'Start measurement with synchronization

CDP:SET 2
'Select results from SET 2

TRAC? TRACE1
'Read out CDP
```

### Characteristics

\*RST value: 1  
SCPI: device-specific

## [SENSe:]CDPower:SLOT 0 ...IQLength-1

This command selects the half slot (and not the whole slot). To ensure compatibility with other 3G mobile radio applications, no new command has been introduced for the half slot (the slot command has simply been reused).

### Example

```
INST:SEL MDO
'Activate 1xEV-DO MS, implicit are CDP relative on Screen A
and Result Summary active on Screen B

INIT:CONT OFF
'Select single sweep

CDP:SLOT 2
'Selects half slot 2

INIT;*WAI
'Start measurement with synchronization
```

### Characteristics

\*RST value: 0  
SCPI: device-specific



**[SENSe:]CDPower:SBANd NORMal | INVers**

This command is used to swap the left and right sideband.

**Example**

```
INST:SEL MDO
'Activate 1xEV-DO MS, implicit are CDP relative on Screen A
and Result Summary active on Screen B

INIT:CONT OFF
'Select single sweep

CDP:SBAN INV
'Swap sidebands

INIT;*WAI
'Start measurement with synchronization
```

**Characteristics**

\*RST value: NORM  
SCPI: device-specific

---

**[SENSe:]CDPower:SET[:VALue] 0 ... (SET COUNT-1)**

With this command the SET is selected for which the results are evaluated. .  
Beforehand with CDP:SET:COUN a SET COUNT value greater than 1 must be set  
This command is only available on R&S FSQ.

**Example**

```
INST:SEL MDO
'Activate 1xEV-DO MS, implicit are CDP relative on Screen A
and Result Summary active on Screen B

INIT:CONT OFF
'Select single sweep

CDP:SET:COUN 12
'Select 12 sets of 64 half slots on R&S FSQ

INIT;*WAI
'Start measurement with synchronization

CDP:SET 2
'Select results from SET 2

TRAC? TRACE1
'Read out CDP
```

**Characteristics**

\*RST value: 0  
SCPI: device-specific

---

**[SENSe:]CDPower:TPMeas ON | OFF**

This command allows specific activation and deactivation of the timing and phase offset evaluation of the channels relative to the pilot channel. If the value is OFF, the TRACe? TRACe1 and CALC:MARK:FUNC:CDP:RES? commands return a value of '9' for the timing and phase offset as the result. If the value is ON, the timing and phase offsets are calculated and returned.

**Example**

```
INST:SEL MDO
'Activate 1xEV-DO MS, implicit are CDP relative on Screen A
and Result Summary active on Screen B

INIT:CONT OFF
'Select single sweep

CDP:TPM ON
'Activate timing and phase offset evaluation

INIT;*WAI
'Start measurement with synchronization

CDP:SLOT 2
'Selects half slot 2
CDP:CODE 11
'Select code number 11

CALC:MARK:FUNC:CDP:RES? TOFF
'Read out timing offset of code with number 11 in half slot 2

CALC:MARK:FUNC:CDP:RES? POFF
'Read out phase offset of code with number 11 in half slot 2
```

**Characteristics**

\*RST value: OFF  
SCPI: device-specific

## 7.8 TRACe Subsystem

### TRACe[:DATA] TRACE1 | TRACE2 | CTABLE

This command transfers trace data from the controller to the instrument, and the query command reads trace data from the instrument.

TRACE1, TRACE2 or CTABLE can be read out, depending on the display.

The trace data (TRACE1 | TRACE2) is formatted as follows for the different displays; CTABLE is described under Channel Table:

CODE DOMAIN POWER ABSOLUT/CODE DOMAIN POWER RELATIV  
(TRACE1):

The following is output for each channel:

Code class	Code class of the channel; with Hadamard order it is usually code class 4. With BitReverse order, values are between 2 and 4
Code number	Code number of channel, values between 0 and 15
Level	<ul style="list-style-type: none"> <li>• For CODE DOMAIN POWER ABSOLUTE, units are dBm</li> <li>• For CODE DOMAIN POWER RELATIVE, units are dB ((referred to the total or pilot power, see the command CDPower:PREference)</li> </ul> <p>Power values of the individual codes are usually given in Hadamard order; the consolidated channel power is returned in BitReverse order.</p>
Power ID	0 - Inactive channel 1 - Active channel 3 - Quasi-inactive channel (on the analyzed branch, the channel is not occupied, but an active channel exists on the other branch)

Four values are thus transferred for all channels:  
<Code class>, <Code number>, <Level>, <Power ID>

The Hadamard or BitReverse order is important for sorting the channels and consolidation (see the command CDPower:ORDER).

With Hadamard, the individual codes are output in ascending order with their code power. The number of codes which are output corresponds to spreading factor 16. With BitReverse, codes which belong to a particular channel are adjacent to each other and are therefore output in the class of the channel together with the channel power. The maximum number of codes or channels that are output cannot be higher than spreading factor 16, and decreases with each concentrated channel..

#### Example

The example shows the results of the query for 2 channels with the following configuration:

```
PICH      0.16  (CC 4)      I      -7.0  dB
DATA    2.4  (CC 2)      Q      -10.0 dB

INST:SEL MDO      'Activate 1xEV-DO MS, implicit are CDP
```

```

relative on Screen A and Result Summary
active on Screen B Mapping set to I
INIT:CONT OFF      'Select single sweep
CDP:MAPP Q         'Select Q branch
CDP:ORD HAD        'Set order to Hadamard
INIT;*WAI          'Start measurement with synchronization
TRAC? TRACE1      'Read out CDP relative/Hadamard/Q
4, 0,-53.3,3,     4, 1,-52.3,0,     'Code 0 is quasi-inactive
                                     since PICH is set to I
4, 2,-16.1,1,    4, 3,-54.6,0,     'The DATA channel is
                                     distributed between the active
4, 4,-51.2,0,     4, 5,-55.1,0,     'Codes 2.16, 6.16, 10.16,
                                     14.16 each with
4, 6,-16.4,1,    4, 7,-51.3,0,     'one quarter of the power,
                                     i.e.
4, 8,-52.4,0,     4, 9,-55.5,0,     '10 dB - 6 dB = -16 dB
4,10,-15.8,1,    4,11,-54.3,0,
4,12,-51.8,0,     4,13,-57.6,0,
4,14,-15.9,1,    4,15,-52.5,0
CDP:ORD BITR      'Set order to BitReverse
TRAC? TRACE1      'Read out CDP relative/BitReverse/Q
                                     'Sorting is changed in accordance with
                                     BitReverse.
4, 0,-53.3,3,     4, 8,-52.4,0,     'PICH is quasi-inactive
4, 4,-51.2,0      4,12,-51.8,0,
2, 2,-10.0,1,
4, 1,-52.3,0,     4, 9,-55.5,0,     ''Channel 2.4 is now
4, 5,-55.1,0,     4,13,-57.6,0,     consolidated and displayed
4, 3,-54.6,0,     4,11,-54.3,0,     with accumulated power.
4, 7,-51.3,0,     4,15,-52.5,0
CDP:OVER ON       'Activate Overview mode
                                     'CDP relative on Screen A I
                                     branch
                                     'CDP relative on Screen B Q
                                     branch
TRAC? TRACE1      'Read out CDP relative of I
                                     branch
4, 0, -7.0,1,     4, 8,-54.2,0,     'PICH is active
4, 4,-56.7,0      4,12,-55.3,0,
4, 2,-48.3,3,    4,10,-48.1,3,    'DATA 2.4 is quasi-inactive
4, 6,-49.0,3,    4,14,-48.5,3,
4, 1,-54.4,0,     4, 9,-55.2,0,
4, 5,-51.2,0,     4,13,-54.3,0,
4, 3,-54.5,0,     4,11,-55.7,0,
4, 7,-56.6,0,     4,15,-52.3,0
TRAC? TRACE2      'Read out CDP relative of Q
                                     branch
4, 0,-53.3,3,     4, 8,-52.4,0,     'PICH is quasi-inactive
4, 4,-51.2,0      4,12,-51.8,0

```

```

2, 2,-10.0,1,          'Channel 2.4 is now
4, 1,-52.3,0, 4, 9,-55.5,0, 'consolidated and displayed
4, 5,-55.1,0, 4,13,-57.6,0, 'with accumulated power.
4, 3,-54.6,0, 4,11,-54.3,0,
4, 7,-51.3,0, 4,15,-52.5,0

```

### CODE DOMAIN ERROR POWER (TRACE1):

The following is output for each channel:

Code class	Code class of the channel is usually 4 since the CDEP is displayed in base spreading factor 16
Code number	Code number of channel, values between 0 and 15
Error power	in dB No difference of power between the Hadamard and BitReverse order
Power ID	0 - Inactive channel 1 - Active channel 3 - Quasi-inactive channel (on the analyzed branch, the channel is not occupied, but an active channel exists on the other branch)

Four values are thus transferred for all channels:

<Code class>, <Code number>, <Level>, <Power ID>

The Hadamard or BitReverse order is important for sorting the channels (see the `CDPower:ORDER` command).

With Hadamard order, the individual codes are output in ascending order.

With BitReverse order, codes which belong to a particular channel are adjacent to each other.

Since an error power is output for the code domain error power, consolidation of the power values is not appropriate. The number of codes that are output therefore generally corresponds to base spreading factor 16.

### Example

The example shows the results of the query for 2 channels with the following configuration:

```

PICH      0.16  (CC 4)      I      -7.0  dB
DATA    2.4  (CC 2)    Q      -10.0 dB

INST:SEL MDO          'Activate 1xEV-DO MS, implicit are
                      CDP relative on Screen A and Result
                      Summary active on Screen B Mapping
                      set to I

INIT:CONT OFF        'Select single sweep
CDP:MAPP Q           'Select Q branch
CALC1:FEED 'XPOW:CDEP' 'Code domain error-power evaluation
INIT;*WAI            'Start measurement with

```

```

                                synchronization
TRAC? TRACE1                    'Read out CDEP Hadamard/Q
4, 0,-52.3,1, 4, 1,-55.0,0, 'PICH is quasi-inactive since
                                it is set to I branch

4, 2,-53.4,0, 4, 3,-55.2,0,
4, 4,-48.3,3, 4, 5,-53.7,3,
4, 6,-49.6,3, 4, 7,-48.8,3,
4, 8,-54.3,0, 4, 9,-56.0,0,
4,10,-52.4,0, 4,11,-47.8,0,
4,12,-55.6,0, 4,13,-52.1,0,
4,14,-50.5,0, 4,15,-48.0,0

```

### CHANNEL TABLE (TRACE1):

The following is output for each channel:

Channel type	The channel type is coded by numbers as follows: 0 = PICH 1 = RRI 2 = DATA 3 = ACK 4 = DRC 5 = INACTIVE
Code class	Code class of channel, values between 2 and 4
Code number	Code number of channel, values between 0 and 15
Mapping	0 = I branch 1 = Q branch
Absolute level	in dBm
Relative level	In dB, referred to the total or pilot power (see the <code>CDPower:PREference</code> command)
Timing offset	Referred to the pilot in seconds
Phase offset	Referred to the pilot in rad If the evaluation of the timing and phase offset is not active (see <code>CDPower:TPMeas</code> ) or more than 50 active channels are in the signal, the value 9 is returned For inactive channels, the value 9 is usually returned.

For inactive channels, the value 9 is usually returned.

The class specifies the spreading factor of the channel:

Class 4 corresponds to spreading factor 16 (symbol rate 76.8 ksps), class 2 to the lowest permissible spreading factor 4 (symbol rate 307.2 ksps).

Eight values are thus transferred for all channels:

<Channel type>, <Code class>, <Code number>, <Mapping>, <Absolute level>,  
<Relative level>, <Timing offset>, <Phase offset>

All detected active channels are output first, followed by the inactive or quasi-active channels. The channels are sorted in ascending code number order (with identical code numbers: the I branch first, followed by the Q branch). The unassigned codes are displayed together with code class 4.

**Example**

The example shows the results of the query for 2 channels with the following configuration:

```
PICH 0.16 (CC 4) I -7.0 dB
DATA 2.4 (CC 2) Q -10.0 dB

INST:SEL MDO 'Activate 1xEV-DO MS, implicit are CDP
              relative on Screen A and Result Summary
              active on Screen B
INIT:CONT OFF 'Select single sweep
CALC1:FEED 'XTIM:CDP:ERR:CTAB'
              'Channel table evaluation
INIT;*WAI 'Start measurement with synchronization
TRAC? TRACE1 'Read out channel table
0 , 0, 4, 0, 0.0, -7.0, 9, 9,
2 , 2, 2, 1, -3.0, -10.0, 9, 9,
5 , 0, 4, 1, -46.3, -53.3, 9, 9,
5 , 1, 4, 0, -48.0, -55.0, 9, 9,
5 , 1, 4, 1, -43.2, -50.2, 9, 9,
5 , 2, 4, 0, -42.0, -49.0, 9, 9,
5 , 3, 4, 0, -47.6, -54.6, 9, 9,
    . . . .
5 ,15, 4, 1, -47.7, -54.7, 9, 9
```

**CHANNEL TABLE (CTABLE):**

In addition to the results of the channel table which are output using the TRACE1 command, active timing and phase offset measurement (see `CDPower:TPMeas`) also has the CTABLE query command which displays the maximum values of the TIMING and PHASE OFFSET together with the associated channel.

The following values are output:

<Max. time offset in s>, <Code number for max. time>, <Code class for max. time>, <Max. phase offset in rad>, <Code number for max. phase>, <Code class for max. phase>, <Reserved 1>, ..., <Reserved 6>

**Example**

```
INST:SEL MDO" 'Activate 1xEV-DO MS, implicit are CDP
              relative on Screen A and Result Summary
              active on Screen B
INIT:CONT OFF" 'Select single sweep
CALC1:FEED 'XTIM:CDP:ERR:CTAB'
              'Channel table evaluation
CDP:TPM ON 'Activate timing and phase offset measurement
INIT;*WAI 'Start measurement with synchronization
TRAC? CTAB 'Read out maximum timing and phase offsets
1.20E-009,2,2, 'Max. Time offset with code number and code
              class of associated channel
-3.01E-003,2,2, 'Max. Phase offset with code number and code
              class of associated channel
```

0,0,0,0,0,0 '6 reserved values

### RESULT SUMMARY (TRACE2):

The results of RESULT SUMMARY are output in the following order:

<SLOT>, <PTOTal>, <PPICH>, <PRRI>, <RHO>, <MACCuracy>, <PCDerror>, <ACTive>, <FERRor>, <FERPpm>, <DRPich>, <RHOVerall>, <TFRame>, <CERRor>, <IQOFFset>, <IQIMbalance>, <SRATe>, <CHANnel>, <SFACTor>, <TOFFset>, <POFFset>, <CDPRelative>, <CDPabsolute>, <EVMRms>, <EVMPeak>

The results have the following meanings and units:

Global results of selected half slot		Global results of all half slots	
SLOT	Half-slot number		
PTOTal	Total power in dBm	FERRor	Frequency error in Hz
PPICH	Pilot power in dBm	FERPpm	Frequency error in ppm
PRRI	RRI power in dBm	DRPich	Delta RRI/PICH in dB
RHO	RHO	CERRor	Chip Rate Error in ppm
MACCuracy	Composite EVM in %	TFRame	Trigger to Frame
PCDerror	Peak code domain error in dB	ACTive	Number of active channels
IQOFFset	IQ offset in %	RHOVerall	RHO over all half slots
IQIMbalance	IQ imbalance in %		

Channel results:

SRATe	Symbol rate in ksps	TOFFset	Timing Offset in s
CHANnel	Channel number	POFFset	Phase Offset in rad
SFACTor	Spreading-factor of channel		
CDPRelative	Channel power relative in dB (relative to total or PICH power, see command <code>CDP:PREF</code> )	CDPabsolute	Channel Power absolute in dBm
EVMRms	Error Vector Magnitude RMS in %	EVMPeak	Error vector magnitude peak in %



The trigger to frame value (`TFRame`) returns a '9' if the trigger is set to FREE RUN.

The timing/phase offset values (`TOFFset`/`POFFset`) return a '9' if the timing and phase offset measurement is switched off (see `CDP:TPM`).

If the RRI is not active, its displayed PRRI value is -200 dBm. In this case, the DRPich is set to -200 dB.

### POWER VS HALFSLOT, PEAK CODE DOMAIN ERR und COMPOSITE EVM (TRACE2):

The number of returned value pairs corresponds to the IQ capture length.  
(See command `CDPower:IQLength`).

POWER VS HALFSLOT: <Half-slot number>,<Level value in dB>, <Half-slot number>, <Level value in dB>,.....;

PEAK CODE DOMAIN ERROR: <Half-slot number>, <Level value in dB>, .....

COMPOSITE EVM: <Half-slot number>, <Value in %>, .....



**SYMBOL EVM (TRACE2):**

The number of values depends on the spreading factor:

Spreading factor 16 : 64 values    Spreading factor 8 : 128 values

Spreading factor 4 : 256 values

<Value in % symbol 0>, <Value in % symbol 1>,.....;

**POWER VS SYMBOL (TRACE2):**

The number of values depends on the spreading factor:

Spreading factor 16 : 64 values    Spreading factor 8 : 128 values

Spreading factor 4 : 256 values

<Value in dBm symbol 0>, <Value in dBm symbol 1>,.....;

**SYMBOL CONST (TRACE2):**

The number of values depends on the spreading factor:

Spreading factor 16 : 64 values    Spreading factor 8 : 128 values

Spreading factor 4 : 256 values

Real and imaginary components are transferred as value pairs.

<re 0>,<im 0>,<re 1>,<im 1>,.....<re n>, <im n>

**COMPOSITE CONST (TRACe2):**

The number of value pairs corresponds to the number of chips from the 1024 chips in a half slot. Real and imaginary components are transferred as value pairs.

<re Chip 0>, <im Chip 0>, <re Chip 1>, <im Chip 1>,.....;

**BITSTREAM (TRACE2):**

The bit stream of a slot is output. A value is read out for each bit (value range 0,1); each symbol consists of one bit for BPSK channels.

Spreading factor 16 : 64 values    Spreading factor 8 : 128 values

Spreading factor 4 : 256 values

If a channel is detected as being inactive, the invalid bits in the bit stream are identified by "9".

Example of a bit stream trace: 0, 0, 1, 0 , 1, 1, 0 ....

## 7.9 STATus-QUEStionable:SYNC-Register

This register contains information on the error situation in the code domain power analysis of the FS-K85 option.

It can be queried with the commands

"STATus:QUEStionable:SYNC:CONDition?" and "STATus:QUEStionable:SYNC[:EVENT]?".

**Table 20 Meaning of bits in STATus:QUEStionable:SYNC register**

Bit No.	Meaning
0	Not used in the FS-K85 application
1	<b>K85 Frame Sync failed</b> This bit is set if synchronization is not possible within the application. The reasons for this can be: Wrongly set frequency Wrongly set level Wrongly set long code mask I or long code mask Q Wrongly set values for <i>INVERT Q</i> or <i>SIDEBAND INV</i> Invalid signal at input
2 to 14	Not used in the application
15	This bit is always 0.

## 7.10 Table of softkeys with assignment of IEC/IEEE bus commands

### 7.10.1 MEAS key or MEAS hotkey

POWER	CONF<1>:CDP:MEAS POW Query of results: CALC<1>:MARK<1>:FUNC:POW:RES? CPOW
ACLR	:CONF<1>:CDP:MEAS ACLR Query of results: :CALC<1>:MARK<1>:FUNC:POW:RES? ACP
NO: OF ADJ CHAN	SENS:POW:ACH:ACP 2
ADJUST SETTINGS	SENS:POW:ACH:PRES ACP CPOW OBW
SWEEP TIME	SWE:TIM 1 s
NOISE CORR ON OFF	SENS:POW:NCORR ON
FAST ACLR ON OFF	SENS:POW:HSP ON
DIAGRAM FULL SIZE	-
ADJUST REV LVL	SENS:POW:ACH:PRES:RLEV
ACLR LIMIT CHECK	CALC:LIM:ACP ON CALC:LIM:ACP:ACH:RES? CALC:LIM:ACP:ALT:RES?
EDIT ACLR LIMIT	CALC:LIM:ACP ON CALC:LIM:ACP:ACH 0dB,0dB CALC:LIM:ACP:ACH:STAT ON CALC:LIM:ACP:ACH:ABS -10dBm,-10dBm CALC:LIM:ACP:ACH:ABS:STAT ON ALC:LIM:ACP:ALT1 0dB,0dB CALC:LIM:ACP:ALT1:STAT ON CALC:LIM:ACP:ALT1:ABS -10dBm,-10dBm CALC:LIM:ACP:ALT1:ABS:STAT ON CALC:LIM:ACP:ALT2 0dB,0dB CALC:LIM:ACP:ALT2:STAT ON CALC:LIM:ACP:ALT2:ABS -10dBm,-10dBm CALC:LIM:ACP:ALT2:ABS:STAT ON
CHANNEL BANDWIDTH	SENS:POW:ACH:BWID 1.2288MHz
ADJ CHAN BANDWIDTH	SENS:POW:ACH:BWID:ACH 30kHz SENS:POW:ACH:BWID:ALT1 30kHz SENS:POW:ACH:BWID:ALT2 30kHz
ADJ CHAN SPACING	SENS:POW:ACH:SPAC:ACH 750kHz SENS:POW:ACH:SPAC:ALT1 1.98MHz SENS:POW:ACH:SPAC:ALT2 4MHz

Table of softkeys with assignment of IEC/IEEE bus commands

ACLR ABS REL	SENS:POW:ACH:MODE ABS
CHAN PWR / HZ	CALC:MARK:FUNC:POW:RES:PHZ ON OFF
POWER MODE	
CLEAR/ WRITE	CALC:MARK:FUNC:POW:MODE WRIT MAXH
MAX HOLD	
SPECTRUM EM MASK	CONF:CDP:MEAS ESpectrum Query of results: :CALC<1>:LIM<1>:FAIL?
LIMIT LINE AUTO	CALC:LIM:ESP:MODE AUTO
LIMIT LINE USER	CALC:LIM<1>:NAME <string> CALC:LIM<1>:UNIT DBM CALC:LIM<1>:CONT[:DATA] <num_value>, <num_value>, ... CALC:LIM<1>:CONT:DOM FREQ CALC:LIM<1>:CONT:TRAC 1 CALC:LIM<1>:CONT:OFF <num_value> CALC:LIM<1>:CONT:MODE REL  CALC:LIM<1>:UPP[:DATA] <num_value>, <num_value>.. CALC:LIM<1>:UPP:STATE ON   OFF CALC:LIM<1>:UPP:OFF <num_value> CALC:LIM<1>:UPP:MARG <num_value> CALC:LIM<1>:UPP:MODE ABS CALC:LIM<1>:UPP:SPAC LIN
	<b>Note:</b>
	- If the y values are entered with the command :CALCulate:LIMit<1>:LOWer[:DATA], the limit check returns "failed" if the values are below the limit line.
	- If a user-defined limit line is activated, this has priority over limit lines which have been selected with AUTO.
RESTORE STD LINES	CALC:LIM:ESP:REST
LIST EVOLUTION	CALC1:PEAK:AUTO ON   OFF With this command the list evaluation which is by default for backwards compatibility reasons off can be turned on.  TRAC1:DATA? LIST With this command the list evaluation results are queried in the following order: <no>, <start>, <stop>, <rbw>, <freq>, <power abs>, <power rel>, <delta>, <limit check>, <unused1>, <unused2>
ADJUST REF LVL	SENS:POW:ACH:PRES:RLEV
30kHz/1MHz TRANSITION	CALC:LIM:ESP:TRAN <numeric value>

Table of softkeys with assignment of IEC/IEEE bus commands

OCCUPIED BANDWIDTH	CONF<1>:CDP:MEAS OBAN Query of results: CALC<1>:MARK<1>:FUNC:POW:RES? OBAN
% POWER BANDWIDTH	:SENS:POW:BWID 99PCT
ADJUST SETTINGS	:SENS:POW:PRES OBW
ADJUST REF LVL	:SENS:POW:ACH:PRES:RLEV
SIGNAL STATISTICS	:CONF:CDP:MEAS CCDF or :CALC:STAT:CCDF[:STATe] ON Query of results: CALC:MARK:X?
APD	CALC:STAT:APD ON
CCDF	CALC:STAT:CCDF ON
PERCENT MARKER	CALC:MARK:Y:PERC 0...100%
NO OF SAMPLES	CALC:STAT:NSAM <value>
SCALING	
X-AXIS REF LEVEL	CALC:STAT:SCAL:X:RLEV <value>
X-AXIS RANGE	CALC:STAT:SCAL:X:RANG <value>
Y-UNIT % ABS	CALC:STAT:SCAL:Y:UNIT PCT
Y-AXIS MAX VALUE	CALC:STAT:SCAL:Y:UPP <value>
Y-AXIS MIN VALUE	CALC:STAT:SCAL:Y:LOW <value>
ADJUST SETTINGS	CALC:STAT:SCAL:AUTO ONCE
DEFAULT SETTINGSL	CALC:STAT:PRES
ADJUST SETTINGS	CALC:STAT:SCAL:AUTO ONCE
CONT MEAS	INIT:CONT ON; INIT:IMM
SINGLE MEAS	INIT:CONT OFF; INIT:IMM

## 7.10.2 RESULTS hotkey or CODE DOM ANALYZER softkey

CODE DOM POWER	CALC<1>:FEED "XPOW:CDP:RAT" (relative) CALC<1>:FEED "XPOW:CDP" (absolute)
CODE DOM ERROR	CALC<1>:FEED "XPOW:CDEP"
COMPOSITE EVM	CALC2:FEED "XTIM:CDP:MACCuracy"
PEAK CODE DOMAIN ERR	CALC2:FEED "XTIM:CDP:ERR:PCDomain"
POWER VS HALF SLOT	CALC2:FEED "XTIM:CDP:PVSLOT"
RESULT SUMMARY	CALC2:FEED "XTIM:CDP:ERR:SUMM" Query of results: CALC<1 2>:MARK<1>:FUNC:CDP:RES? PTOT   FERR   RHO   PPIC   PRRI   FERP   DRP   RHOOverall   CERRor  TFRame   IQOF   IQIMbalance   MACCuracy   PCD   SLOT   ACTive   SRATE  TOFF  CHAN   POFF   SFAC   CDP   CDPR   EVMRms   EVMP
CHANEL TABLE	CALC<1>:FEED "XTIM:CDP:ERR:CTAB"
SYMBOL CONST	CALC2:FEED "XTIM:CDP:SYMB:CONS"
SYMBOL EVM	CALC2:FEED "XTIM:CDP:SYMB:EVM"
BITSTEAM	CALC2:FEED "XTIM:CDP:BSTream"
COMPOSITE CONST	CALC2:FEED "XTIM:CDP:COMP:CONS"
POWER VS SYMBOL	CALC2:FEED "XTIM:CDP:PVSY"
SELECT I Q	[SENS:]CDP:MAPP...I   Q
SELECT CHANNEL	[SENS:]CDP:CODE 0... (BASE SF-1)
SELECT	
CAPTURE LENGTH	[SENS:]CDP:IQL 2..70
SET COUNT	[SENS:]CDP:SET:COUN 1..57 (only R&S FSQ)
SET TO ANALYZE	[SENS:]CDP:SET:[VAL] 0..(SET COUNT-1) (only R&S FSQ)
SELECT CHANNEL	[SENS:]CDP:CODE 0... (BASE SF-1)

Table of softkeys with assignment of IEC/IEEE bus commands

SELECT HALF SLOT	[SENS:]CDP:SLOT 0 ... (IQ_CAPTURE_LENGTH-1)
ADJUST REF LVL	SENS:POW:ACH:PRES:RLEV

### 7.10.3 CHAN CONF hotkey

CODE CHAN AUTOSEARCH	CONF:CDP:CTAB[:STAT] OFF
CODE CHAN PREDEFINED	CONF:CDP:CTAB[:STAT] ON CONF:CDP:CTAB:SEL <channel table name>
EDIT CHAN CONF TABLE	---
HEADER VALUES	CONF:CDP:CTAB:e:NAME "NEW_TAB"
INSERT LINE	---
DELETE LINE	---
SAVE TABLE	--
SORT TABLE	---
PAGE UP	---
PAGE UP	---
DEL CHAN CONF TABLE	CONF:CDP:CTAB:DEL
COPY CHAN CONF TABLE	CONF:CDP:CTAB:e:COPY "CTAB2"
RESTORE STD TABLES	CONF:CDP:CTAB:REST"

### 7.10.4 SETTINGS hotkey

BAND CLASS	CONF:CDP:BCL 1 '1900 MHz
CAPTURE SETTINGS	
CAPTURE LENGTH	[SENS:]CDP:IQL 2..70

Table of softkeys with assignment of IEC/IEEE bus commands

SET COUNT	[SENS:]CDP:SET:COUN 1..57 (nur R&S FSQ)
SET TO ANALYZE	[SENS:]CDP:SET:[VAL] 0..(SET COUNT-1) (nur R&S FSQ)
SELECT CHANNEL	[SENS:]CDP:CODE 0...(BASE SF-1)
SELECT HALF SLOT	[SENS:]CDP:SLOT 0 ...(IQ_CAPTURE_LENGTH-1)
CDP AVG ON OFF	[SENS:]CDP:AVER ON   OFF
ORDER HADAMBITRE	[SENS:]CDP:ORDeR HAD   BITR
CODE DOM OVERVIEW	[SENS:]CDP:OVER ON   OFF
SELECT I Q	[SENS:]CDP:MAPP I   Q
CODE PWR ABS REL	CALC<1>:FEED "XPOW:CDP:RAT" (relative) CALC<1>:FEED "XPOW:CDP" (absolute)
POWER REF TOT PICH	[SENS:]CDP:PREFeRence TOTal   PICH
ORDER HADAMBITRE	[SENS:]CDP:ORDeR HAD   BITR
TIME PHASE ON OFF	[SENS:]CDP:TPMeas ON   OFF
LOG CODE I	[SENS:]CDP:LCOde:I ..... '#H0' ... '#H3FFFFFFFF'
LOG CODE Q	[SENS:]CDP:LCOde:Q'#H0' ... '#H3FFFFFFFF8000'
INACT CHAN THRESHOLD	[SENS:]CDP:ICTReshold -100 dB ... 0 dB
INVERT Q ON OFF	[SENS:]CDP:QINVert ON   OFF
SIDE BAND NORN INV	[SENS:]CDP:SBAN NORM INVers
NORMALIZE ON OFF	[SENS:]CDP:NORM ON   OFF
OPERATIOM ACCES	
OPERATIOM TRAFIC	[SENS:]CDP:OPERATION ACC   TRAF



## 8 Checking the Rated Specifications

- Switch off the analyzer before removing or inserting modules.
- Check the position of the mains voltage selector before switching on the instrument.
- Measure the rated specifications after a warm-up time of at least 30 minutes and completion of system error correction of the analyzer and the R&S SMIQ. Only then can it be ensured that the specifications are complied with.
- Unless otherwise specified, all settings are made starting from the PRESET setting.

The following conventions apply to settings on the analyzer during measurement:

- [<KEY>] Press a key on the front panel, e.g. [SPAN].
- [<SOFTKEY>] Press a softkey, e.g. [MARKER -> PEAK].
- [<nn unit>] Enter a value + terminate the entry with the unit, e.g. [12 kHz].
- {<nn>} Enter values provided in one of the following tables.

Successive entries are separated by [:], e.g. [**SPAN**: 15 kHz].

The values in the following sections are not guaranteed. Only the specifications in the data sheet are binding.

### 8.1 Measuring equipment and accessories

Item	Instrument type	Recommended specifications	Recommended instrument	R&S order No.
1	Signal Generator	Vector signal generator	R&S SMIQ mit Optionen: R&S SMIQB20 R&S SMIQB11 R&S SMIQB60 R&S SMIQK17 R&S SMIQ-Z5 PARADATA	1125.5555.xx 1125.5190.02 1085.4502.04 1136.4390.02 1154.7800.02 1104.8555.02
2	Controller for generating signals with WinIQSIM C that is either connected by means of a serial cable to the R&S SMIQ, or has an IEC/IEEE bus card and connected by means of an IEC/IEEE bus cable to the R&S SMIQ. R&S WinIQSIM software V3.91 must be installed on the PC. The software can be downloaded from the Rohde & Schwarz web site on the Internet at <a href="http://www.rohde-schwarz.com">http://www.rohde-schwarz.com</a> .			

## 8.2 Test sequenceuf

The performance test refers exclusively to results of the code domain analyzer

Eine Überprüfung der Messwerte der POWER-, ACLR- und SPECTRUM-Messungen ist nicht erforderlich, da sie bereits durch den Performance Test des Grundgerätes abgedeckt werden.

If not done already, the WinIQSIM file with the 1xEV-DO MS signal must be created first and transferred to the R&S SMIQ as "DOMS". This is described at length in the section "Generating a 1xEV-DO reverse link signal with WinIQSIM" on page 10.

### Default settings on R&S SMIQ:

#### [PRESET]

[LEVEL: 0 dBm]

[FREQ: 833.49 MHz]

ARB MOD

SET SMIQ ACCORDING TO WAVEFORM ...

SET SMIQ ACCORDING TO WAVEFORM ON

IQ SWAP (VECTOR MODE) ON

TRIGGER OUT MODE ON



These 3 settings are only needed once after presetting the generator and are used to apply, in VECTOR MODE, the IQ SWAP and, in ARB MOD, the trigger setting automatically from the waveform file generated by WinIQSIM. This is especially convenient when changing between different waveforms.

SELECT WAVEFORM... Name 'DOMS' auswählen

STATE: ON

### Default settings on analyzer:

#### [PRESET]

[CENTER: 833.49 MHz]

[AMPT: 10 dBm]

[1xEVDO MS]

[TRIG EXTERN]

[SETTINGS TIME/PHASE: ON]

[RESULTS CHANNEL TABLE]

**Test setup and other settings**

1. Connect the RF output of the SMIQ to the RF input of the analyzer.
2. Connect the external trigger input of the analyzer to the TRIG1 port of the Z5 PARDATA BNC Adapter.
3. Connect the external reference output of the analyzer to the R&S SMIQ.

**R&S SMIQ**

*UTILITIES*

*REF OSC*

*SOURCE: EXT*

**Analyzer**

**[SETUP: REFERENCE INT]**

The measurement result displayed on the screen of the analyzer should have the following appearance:

 MS,DO,C0 :CHANNEL TAB

Chan 0.16 -I Max T 0.09 ns @ RRI 0.16  
 CF 833.49 MHz Half Slot 0 Max Ph -1.18 mrad @ RRI 0.16

Type	Chan.SF	Symb Rate	Map	Status	Pwr Abs	Pwr Rel	T Offs	Ph Offs
		ksp			dBm	dB	ns	mrad
Ref	PILOT	0.16	76.8	I active	-1.09	-0.79	0.00	0.00
10.0 dBm	RRI	0.16	76.8	I active	-1.10	-0.80	0.09	-1.18
	DATA	2.4	307.2	Q active	-8.10	-7.79	-0.01	-0.01
Att		0.16	76.8	Q inact	-57.01	-56.71	-	-
40 dB		1.16	76.8	I inact	-60.25	-59.95	-	-
		1.16	76.8	Q inact	-58.20	-57.89	-	-
		2.16	76.8	I inact	-56.46	-56.15	-	-
		3.16	76.8	I inact	-58.42	-58.11	-	-
1		3.16	76.8	Q inact	-58.56	-58.26	-	-
CLRWR		4.16	76.8	I inact	-56.17	-55.86	-	-
		4.16	76.8	Q inact	-59.01	-58.70	-	-
		5.16	76.8	I inact	-58.38	-58.07	-	-

**RESULT SUMMARY TABLE**

SR 76.8 ksp  
 Chan 0.16 -I  
 CF 833.49 MHz Half Slot 0

Results for Half Slot: 0		Global results	
Total PWR	-0.31 dBm	Carr Freq Error	-53.80 mHz
Pilot PWR	-1.09 dBm	Carr Freq Error	-0.00 ppm
RRI PWR	-1.10 dBm	DELTA RRI/PICH	0.00 dB
RHO	0.99994	RHO overall	0.99994
Composite EVM	0.81 %	Trg to Frame	-201.566593 ns
Pk CDE (SF 16/I)	-53.82 dB	Chip Rate Err	0.01 ppm
IO Imbal/Offset	0.08/0.07 %	Active Channels	3
Channel results		Mapping	
Symbol Rate	76.8 ksp	Timing Offset	0.00 ns
Channel.SF	0.16	Phase Offset	0.00 mrad
Channel Power Rel	-0.79 dB	Channel Power Abs	-1.10 dBm
Symbol EVM	0.22 % rms	Symbol EVM	0.66 % Pk

## 9 Code Table for Hadamard and BitReverse Order

The following tables show the code sequences for the Hadamard and BitReverse order for the code domain power and code domain error-power evaluations.

Using channel 2.4 as an example (channel number 2 with spreading factor 4), the highlighted entries indicate where the individual codes of this channel are located.

**Table 21** Code table for base spreading factor 16

HADAMARD				BITREVERSE			
0	0000	0	0	0	0	0000	0
1	0001	0	0	0	1	1000	8
<b>2</b>	0010	0	0	1	0	0100	4
3	0011	0	0	1	1	1100	12
4	0100	0	1	0	0	<b>0010</b>	<b>2</b>
5	0101	0	1	0	1	<b>1010</b>	<b>10</b>
<b>6</b>	0110	0	1	1	0	<b>0110</b>	<b>6</b>
7	0111	0	1	1	1	<b>1110</b>	<b>14</b>
8	1000	1	0	0	0	0001	1
9	1001	1	0	0	1	1001	9
<b>10</b>	1010	1	0	1	0	0101	5
11	1011	1	0	1	1	1101	13
12	1100	1	1	0	0	0011	3
13	1101	1	1	0	1	1011	11
<b>14</b>	1110	1	1	1	0	0111	7
15	1111	1	1	1	1	1111	15

## Glossary

1xEV-DO	First <u>E</u> volution <u>D</u> ata <u>O</u> nly
ACK	Reverse acknowledgment channel
CDEP	Code domain error power
CDP	Code-domain power
Composite EVM	According to the 3GPP specifications, the composite EVM measurement determines the square root of the squared error between the real and imaginary components of the test signal and of an ideally generated reference signal (EVM referred to the total signal).
Crest-Faktor	Ratio of peak to average value of the signal
DATA	Reverse data channel
DRC	Reverse data rate control channel
MC1	Multi Carrier1 (carrier system 1X)
PICH	Reverse pilot channel 0.16 on the I branch
RRI	Reverse rate indicator
SF	Spreading factor
x.y	Walsh code x.y, where: x is the code number and y is the spreading factor of the channel.

# Index

## A

Activity.....	73
Amplitude power distribution.....	47, 48
Amplitude probability distribution function.....	47, 48
Attenuation	
Mechanical.....	81
Average.....	85

## B

Bit stream.....	67
-----------------	----

## C

Carr Freq Err.....	63
CCDF	
Complementary cumulative distribution function.....	47, 48
Center frequency.....	80
Chan #.....	65
Channel.....	64
Active.....	79
Bandwidth.....	36, 37
Spacing.....	37
Status.....	73
Channel occupancy table.....	64
Channel power.....	29
Absolute/relative.....	38
Channel type.....	72
Checking rated specifications.....	126
Chip Rate Err.....	63
Code domain error power.....	58
Code domain power.....	55
Commands	
Assignment to softkeys.....	120
Complementary distribution function.....	48
Composite constellation.....	68
Composite EVM.....	63

## D

<i>DEFAULT</i> .....	71
Default setting.....	12
Scaling on x and y-axis.....	50
Distribution function.....	48
Distribution function of signal amplitudes.....	47, 48

## E

Error Vector Mag Pk / rms.....	64
--------------------------------	----

## F

Fast power measurement.....	34
Frequency	
Offset.....	80
Function fields.....	55

## H

HALF SLOT.....	70, 77
Hotkey	
<i>CDMA2k MS</i> .....	25
<i>CHAN CONF</i> .....	24, 25, 71
<i>MEAS</i> .....	25, 28
<i>RESULTS</i> .....	25, 53
<i>SETTINGS</i> .....	25

## I

index entry	
subentry.....	129
IQ Imbalance.....	63
IQ Offset.....	63

## K

### Key

<i>AMPT</i> .....	81
<i>BW</i> .....	84
<i>CAL</i> .....	87
<i>DISP</i> .....	86
<i>FILE</i> .....	87
<i>FREQ</i> .....	80
<i>HCOPY</i> .....	87
<i>LINES</i> .....	86
<i>MARKER</i> .....	82
<i>MEAS</i> .....	28, 84
<i>MKR FCTN</i> .....	84
<i>MKR</i> →.....	83
<i>SETUP</i> .....	87
<i>SPAN</i> .....	80
<i>SWEEP</i> .....	84
<i>TRACE</i> .....	85
<i>TRIG</i> .....	84

## L

Limit	
ACP measurement.....	35
Probability range.....	49
Limit check	
ACLR measurement.....	35

## M

Mapping.....	64, 65
Marker	
Maximum.....	83
Max Hold.....	85
Maximum search.....	83
Menu overview.....	25
Min Hold.....	85

## N

No of Active Chan.....	63
------------------------	----

Number of active channels.....	63	<i>CAPTURE LENGTH</i> .....	69, 76
<b>O</b>		<i>CAPTURE LENGTH</i> .....	59, 60, 61
Offset		<i>CAPTURE LENGTH</i> .....	104
Reference level.....	81	<i>CAPTURE SETTINGS</i> .....	76
Overwrite mode .....	85	CCDF .....	94, 101
<b>P</b>		<i>CCDF ON/OFF</i> .....	48
Peak code domain error.....	60, 63	<i>CDP AVG</i> .....	56
Peak value detection.....	85	<i>CDP AVG ON/OFF</i> .....	77
Performance Test .....	126	CENTER.....	80
Phase Offset.....	64, 65	<i>CF STEPSIZE</i> .....	80
Pilot channel.....	84	CF-STEPsize .....	80
Pilot Power .....	62	<i>CHAN PWR / HZ</i> .....	38
Power		CHAN TABLE HEADER .....	96
1xEV-DO signal.....	38	<i>CHAN TABLE VALUES</i> .....	97
Ref. to 1 Hz bandwidth.....	38	<i>CHANNEL BANDWIDTH</i> .....	36
Power bandwidth		<i>CHANNEL TABLE</i> .....	64, 88, 112
Percentage.....	46	<i>CLEAR/WRITE</i> .....	85
Power measurement		<i>CODE CHAN AUTOSEARCH</i> .....	71
Fast.....	34	<i>CODE CHAN PREDEFINED</i> .....	71, 100
Power versus symbol.....	68	<i>CODE DOM ANALYZER</i> .....	28, 101
Preset.....	12	CODE DOM ERROR .....	58
PWR ABS / PWR REL.....	65	<i>CODE DOM ERROR</i> .....	88
<b>R</b>		<i>CODE DOM OVERVIEW</i> .....	78
Radio configuration.....	73	CODE DOM POWER .....	55, 88, 112
Rated specifications.....	126	<i>CODE PWR ABS/REL</i> .....	78
Reference level.....	81	COMPOSITE CONST.....	68
Offset.....	81	<i>COMPOSITE EVM</i> .....	59, 88, 112
Remote control .....	88	CONT MEAS.....	50
RF attenuation		<i>COPY CHAN CONF TABLE</i> .....	74, 97
Mechanical .....	82	<i>DEFAULT SETTINGS</i> .....	50
RHO .....	62	<i>DEL CHAN CONF TABLE</i> .....	74, 98
RRI Power .....	62	DELETE LINE.....	73
<b>S</b>		<i>DIAGRAM FULL SIZE</i> .....	35
Scaling.....	49	<i>EDIT ACLR LIMITS</i> .....	35
Search		EDIT CHAN CONF TABLE .....	71, 99
Maximum.....	83	FAST ACLR ON/OFF .....	34
Signal amplitudes, distribution function .....	47, 48	FREQUENCY OFFSET .....	80
Signal statistics.....	47, 48	<i>HEADER/VALUES</i> .....	72
Softkey		<i>INACT CHAN THRESHOLD</i> .....	79, 103
<i>% POWER BANDWIDTH</i> .....	46	<i>INSTALL OPTION</i> .....	8
<i>ACLR</i> .....	28, 30, 101	INVERT Q .....	109
<i>ACLR ABS / REL</i> .....	38	<i>INVERT Q ON / OFF</i> .....	79
<i>ACLR LIMIT CHECK</i> .....	35	LIMIT LINE AUTO.....	40, 90
<i>ADD PICH</i> .....	73	LIMIT LINE MANUAL.....	90
<i>ADJ CHAN BANDWIDTH</i> .....	37	LIMIT LINE USER.....	42, 90
<i>ADJ CHAN SPACING</i> .....	37	<i>LIST EVALUATION</i> .....	43
<i>ADJUST REF LEVEL</i> .....	81	LONG CODE .....	78
<i>ADJUST REF LVL</i> .....	35, 44, 46, 70	LONG CODE I .....	104
<i>ADJUST SETTINGS</i> .....	32, 46, 50	LONG CODE Q .....	105
<i>ALL MARKER OFF</i> .....	82	<i>MARKER -&gt; PICH</i> .....	84, 93
<i>APD ON/OFF</i> .....	48	<i>MARKER 1-4</i> .....	82
<i>AVERAGE</i> .....	85	<i>MARKER NORM/DELTA</i> .....	82
<i>BAND CLASS</i> .....	75, 95	<i>MAX HOLD</i> .....	85
<i>BITSTREAM</i> .....	67, 88, 112	<i>MIN HOLD</i> .....	85
		<i>NEW CHAN CONF TABLE</i> .....	74, 99
		<i>NEXT PEAK</i> .....	83
		<i>NO OF SAMPLES</i> .....	49, 94
		<i>NO. OF ADJ CHAN</i> .....	32
		<i>NOISE CORR ON/OFF</i> .....	34
		<i>NORMALIZE ON / OFF</i> .....	80

NORMALIZE ON/OFF .....	106
OCCUPIED BANDWIDTH .....	28, 44, 101
ORDER .....	77, 107
PEAK .....	83
PEAK CODE DOMAIN ERR .....	60, 88, 112
PEAK MODE MIN / MAX .....	83
PERCENT MARKER .....	48
POWER .....	28, 29, 101
POWER MODE .....	38
POWER REF TOT/PICH .....	78
POWER VS HALF SLOT .....	61, 88, 112
POWER VS SYMBOL .....	68, 88
REF LEVEL .....	81
REF LEVEL OFFSET .....	81
REF VALUE POSITION .....	81
RESTORE STD LINES .....	43
RESTORE STD TABLES .....	74, 99
RESULT DISPLAY .....	88
RESULT SUMMARY .....	62, 88, 112
RF ATTEN AUTO .....	82
RF ATTEN MANUAL .....	81
SAVE TABLE .....	73
SCALING .....	49
SELECT .....	69
SELECT CHANNEL .....	68, 69, 76, 103
SELECT HALF SLOT .....	70, 77, 110
SELECT I/Q .....	78
SELECT MARKER .....	83
SET COUNT .....	69, 76, 109
SET TO ANALYZE .....	111
SET TO ANALYZE .....	69, 76, 109, 111
SETTINGS .....	75
SIDEBAND NORM / INV .....	79, 110
SINGLE MEAS .....	50
SORT TABLE .....	74
SPECTRUM EM MASK .....	28, 38, 101
STATISTICS .....	28, 47
SWEEP COUNT .....	86
SWEEP TIME .....	34
SYMBOL CONST .....	88, 112
SYMBOL CONST .....	66
SYMBOL EVM .....	66, 88, 112
TIME/PHASE .....	78
TIME/PHASE ON / OFF .....	111
VIEW .....	86
X-AXIS RANGE .....	49
X-AXIS REF LEVEL .....	49
Y MAX .....	95
Y MIN .....	95
Y PER DIV .....	81
Y-AXIS MAX VALUE .....	49
Y-AXIS MIN VALUE .....	50
Special channels .....	72
Spreading code .....	64
Status .....	65
STATus-QUEStionable-SYnc-Register .....	119
Symbol constellation .....	66
Symbol error vector magnitude .....	66
Symbol rate .....	63, 65, 72
<b>T</b>	
Test setup .....	22
Timing Offset .....	64, 65
Total power .....	38
Total Power .....	62
Trace	
Overwrite mode .....	85
Peak value detection .....	85
Transducer .....	87
Trg to Frame .....	63
<b>V</b>	
VIEW .....	86